

ELITE series doorstyles

4-02 Elite series wood doorstyles

SOLID WOOD DOOR LIST and DRAWER OPTIONS					
door name	standard drawer front	optional 3-part drawer front	optional 5-part drawer front	optional 5/4-inch Statesman Elite	upgraded drawer front shown
Addison	slab		x		x
Alexandria	slab		x		x
Ashland [french miter]	5-part				
Aspen Ridge	5-part				
Balfour	5-part			x	x
Bondurant	5-part				
Brooklyn [french miter]					
Cambridge	5-part				
Clayton	slab	x			
Cologne	5-part				
Conrad	slab	x	x		x
Cresta [french miter]					
Del Rio [french miter]					
Holston	5-part			x	x
Houghton	slab	x			x
Juilliard	5-part				
Manor [french miter]					
Meridian (updated Navarone)	slab		x		x
Montana	slab		x		x
Odessa	slab		x		
Plaza	slab	x	x		x
Rio Verde [french miter]					
Schaumberg	slab		x		x
Slater	slab		x		x
Vision	slab/molding		x		

4-04 Elite series wood doorstyles KEY

ADDISON-30

Doorstyle Name

Price Level Indicators
 Shaded icons range from 1 to 5.
 One is a lowest price door.
 Five is a highest price door.





KEY

DRAWER FRONT OPTIONS

DRAWER FRONT information
 Choices vary from doorstyle to doorstyle. This information refers to drawer fronts ONLY.

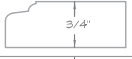
DOOR information
 DOOR information refers to this doorstyle ONLY.

DRAWER FRONT





OUTSIDE EDGE PROFILE	D30	
PANEL PROFILE	PR324-10	
RAILS	SR101	
STILES	SR101	
APPLIED MOLDING	387	

CONSTRUCTION

EDGE TREATMENTS

DOOR

WOOD SPECIES

OUTSIDE EDGE PROFILE	D30	
PANEL PROFILE	PR324-10	
RAILS	SR101	
STILES	SR101	
APPLIED MOLDING	387	

CENTER PANEL

FINISHES

OPTIONS

MINIMUM REQUIREMENTS

Detail Information

This area describes construction details, woods and other information about the doorstyle on this page.

ADDISON-30

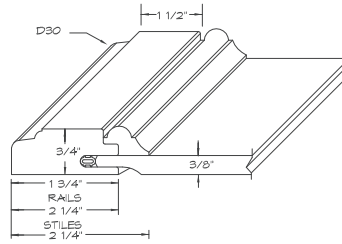

DRAWER FRONT
[UPCHARGE SHOWN]

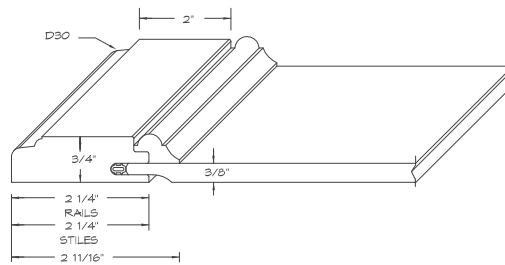

DOOR

DRAWER FRONT OPTIONS



SLAB [STANDARD]



3-PIECE [UPCHARGE]

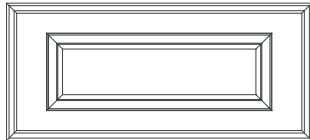

5-PIECE [UPCHARGE]



5/4 STATESMEN [UPCHARGE]

DRAWER FRONT

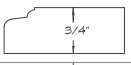
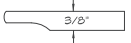
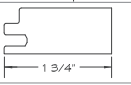
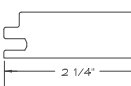
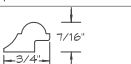
OUTSIDE EDGE PROFILE	D30	
PANEL PROFILE	PR324-10	
RAILS	SR101	
STILES	SR101	
APPLIED MOLDING	387	

CONSTRUCTION

MORTISE AND TENON JOINTS
3/8-INCH THICK WOOD CENTER PANEL
3/4-INCH THICK STILES AND RAILS
2 1/4-INCH WIDE STILES AND RAILS
APPLIED MOLDING

EDGE TREATMENTS

ADDITIONAL EDGES AVAILABLE

WOOD SPECIES

PLEASE SEE CHARTS ON PAGES 3-02 thru 3-04

CENTER PANEL

SOLID WOOD CENTER PANEL
MDF IN PAINTED FINISHES

FINISHES

PLEASE SEE CHARTS ON PAGES 3-04 thru 3-06

OPTIONS

WAINSCOT AVAILABLE
FRAME DOORS AVAILABLE

MINIMUM REQUIREMENTS

DOOR 8" X 8"
DRAWER SLAB 8" X 6 3/4"
DRAWER 3-PIECE N/A
DRAWER 5-PIECE 8" X 6 3/4"
DRAWER 5/4 STATESMAN N/A

DOOR

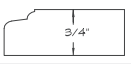
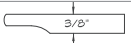
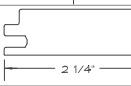
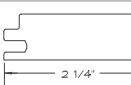
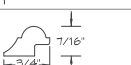
OUTSIDE EDGE PROFILE	D30	
PANEL PROFILE	PR324-10	
RAILS	SR101	
STILES	SR101	
APPLIED MOLDING	387	

4-06 Elite series
alexandria doorstyle

ALEXANDRIA-30

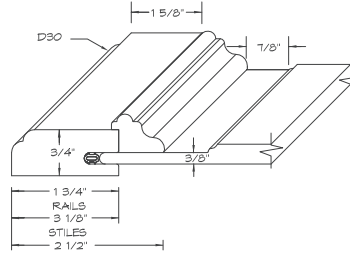

DRAWER FRONT
[UPCHARGE SHOWN]

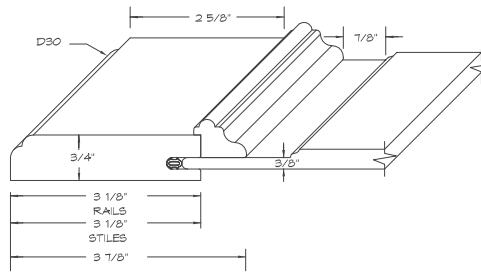

DOOR

DRAWER FRONT OPTIONS



SLAB [STANDARD]



3-PIECE [UPCHARGE]

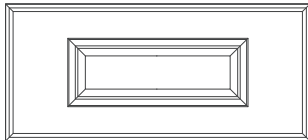

5-PIECE [UPCHARGE]



5/4 STATESMEN [UPCHARGE]

DRAWER FRONT

OUTSIDE EDGE PROFILE	D30	
PANEL PROFILE	PR324-10	
RAILS	SR100	
STILES	SR100	
APPLIED MOLDING	807	

CONSTRUCTION

MORTISE AND TENON JOINTS
3/8-INCH THICK WOOD CENTER PANEL
3/4-INCH THICK STILES AND RAILS
3 1/8-INCH WIDE STILES AND RAILS
APPLIED MOLDING

CENTER PANEL

SOLID WOOD CENTER PANEL
MDF IN PAINTED FINISHES

OPTIONS

WAINSCOT AVAILABLE
FRAME DOORS AVAILABLE

EDGE TREATMENTS

ADDITIONAL EDGES AVAILABLE

WOOD SPECIES

PLEASE SEE CHARTS ON PAGES 3-02 thru 3-04

FINISHES

PLEASE SEE CHARTS ON PAGES 3-04 thru 3-06

MINIMUM REQUIREMENTS

DOOR 12" X 12"
DRAWER SLAB 9" X 6 3/4"
DRAWER 3-PIECE N/A
DRAWER 5-PIECE 12" X 6 3/4"
DRAWER 5/4 STATESMAN N/A

DOOR

OUTSIDE EDGE PROFILE	D30	
PANEL PROFILE	PR324-10	
RAILS	SR100	
STILES	SR100	
APPLIED MOLDING	807	

Elite series 4-07
ashland [french miter] doorstyle

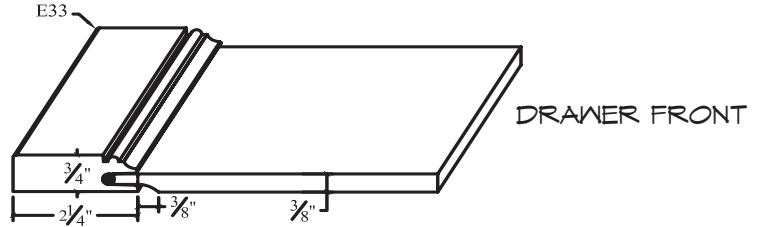

DRAWER FRONT

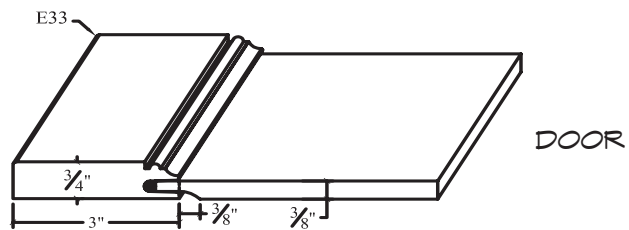

DOOR

DRAWER FRONT OPTIONS

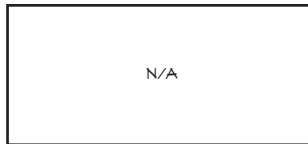

SLAB [UPCHARGE]

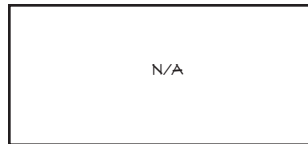

3-PIECE [UPCHARGE]

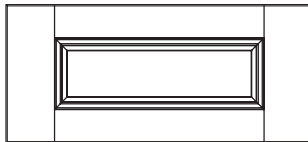

5-PIECE [STANDARD]

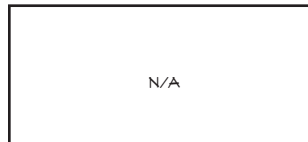

5/4 STATESMAN [UPCHARGE]

DRAWER FRONT

OUTSIDE EDGE PROFILE	D33	
PANEL PROFILE	PR324-10	
RAILS	MP678-57	
STILES	MP678-76	
APPLIED MOULDING		

CONSTRUCTION

3/8-INCH THICK WOOD CENTER PANEL
3/4-INCH THICK WOOD STILES AND RAILS
3-INCH WIDE STILE AND RAILS

FRONT WILL ACCEPT DOOR ADJUSTERS

CENTER PANEL

SOLID WOOD CENTER PANEL
MDF IN PAINTED FINISHES

OPTIONS

FULL OVERLAY 1/4" REVEAL TOP

EDGE TREATMENTS

WOOD SPECIES

PLEASE SEE CHARTS ON PAGES 3-02 thru 3-04

FINISHES

PLEASE SEE CHARTS ON PAGES 3-04 thru 3-06.
NATURE'S OWN IS STANDARD.

MINIMUM REQUIREMENTS

DOOR

OUTSIDE EDGE PROFILE	D33	
PANEL PROFILE	PR324-10	
RAILS	MP678-76	
STILES	MP678-76	
APPLIED MOULDING		

4-08 Elite series
aspen ridge doorstyle

ASPEN RIDGE

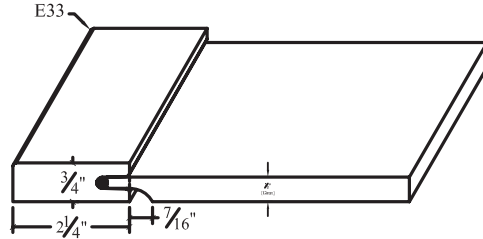

DRAWER FRONT

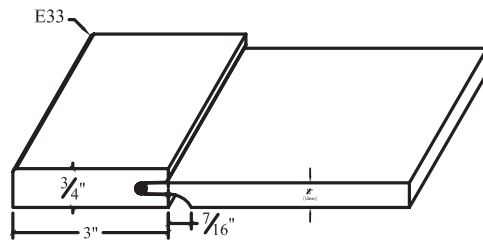

DOOR

DRAWER FRONT OPTIONS

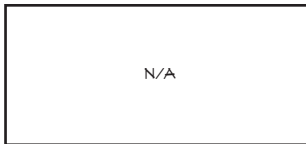

SLAB [UPCHARGE]



3-PIECE [UPCHARGE]

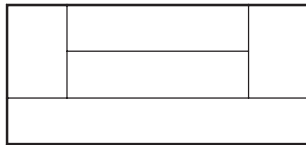

5-PIECE [STANDARD]

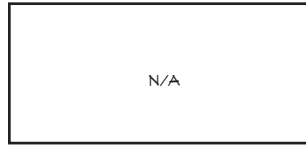

5/4 STATESMAN [UPCHARGE]

DRAWER FRONT

OUTSIDE EDGE PROFILE	D33	
PANEL PROFILE	FR324-10	
RAILS	SR123	
STILES	SR123	
APPLIED MOULDING		

CONSTRUCTION

1/2-INCH THICK WOOD CENTER PANEL
1-INCH THICK WOOD STILES AND RAILS
3-INCH WIDE STILE AND RAILS

FRONT WILL ACCEPT DOOR ADJUSTERS

EDGE TREATMENTS

WOOD SPECIES

PLEASE SEE CHARTS ON PAGES 3-02 thru 3-04

FINISHES

PLEASE SEE CHARTS ON PAGES 3-04 thru 3-06

CENTER PANEL

SOLID WOOD CENTER PANEL
MDF IN PAINTED FINISHES

OPTIONS

FULL OVERLAY 1/4" REVEAL TOP

DOOR

OUTSIDE EDGE PROFILE	D33	
PANEL PROFILE	FR324-10	
RAILS	SR123	
STILES	SR123	
APPLIED MOULDING		

MINIMUM REQUIREMENTS

Elite series 4-09 balfour doorstyle

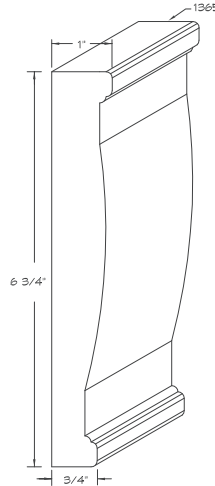

DRAWER FRONT
[UPCHARGE SHOWN]

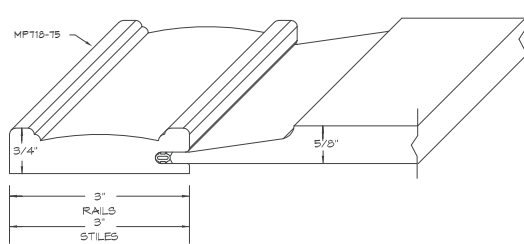

DOOR

DRAWER FRONT OPTIONS

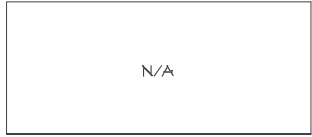

SLAB



3-PIECE [UPCHARGE]



5-PIECE [STANDARD]



5/4 STATESMEN [UPCHARGE]

DRAWER FRONT

OUTSIDE EDGE PROFILE	N/A	
PANEL PROFILE	N/A	
RAILS	N/A	
STILES	N/A	
DRAWER STYLE	1365	
APPLIED MOLDING	N/A	

CONSTRUCTION

- MITERED CORNER
- 5/8-INCH RAISED CENTER PANEL
- 3/4-INCH THICK STILES AND RAILS
- 3- INCH WIDE STILE AND RAILS
- FIVE-PIECE DRAWER FRONT:
- 2 1/4- INCH WIDE RAILS
- 2 1/4- INCH WIDE STILES

CENTER PANEL

- SOLID WOOD CENTER PANEL
- MDF IN PAINTED FINISHES

OPTIONS

- WAINSCOT NOT AVAILABLE
- FRAME DOORS AVAILABLE

EDGE TREATMENTS

WOOD SPECIES

PLEASE SEE CHARTS ON PAGES 3-02 thru 3-04

FINISHES

PLEASE SEE CHARTS ON PAGES 3-04 thru 3-06

MINIMUM REQUIREMENTS

- DOOR 12" X 12"
- DRAWER SLAB N/A
- DRAWER 3-PIECE N/A
- DRAWER 5-PIECE 12" X 6 3/4"
- DRAWER 5/4 STATESMAN 9" X 6 3/4"

DOOR

OUTSIDE EDGE PROFILE	N/A	
PANEL PROFILE	PR229	
RAILS	MP718-75	
STILES	MP718-75	
APPLIED MOLDING	N/A	

4-10 Elite series
bondurant doorstyle

BONDURANT-33

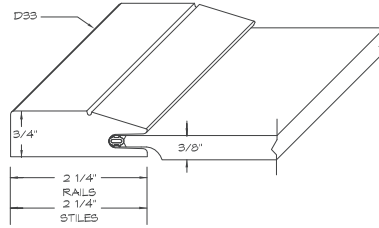

DRAWER FRONT

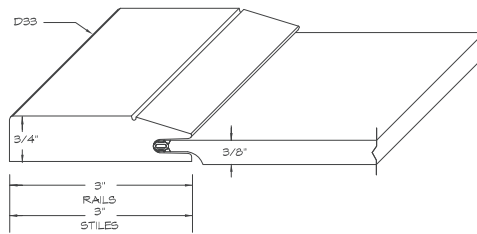

DOOR

DRAWER FRONT OPTIONS



SLAB



3-PIECE [UPCHARGE]

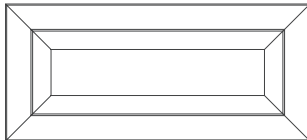

5-PIECE [STANDARD]



5/4 STATESMEN [UPCHARGE]

DRAWER FRONT

OUTSIDE EDGE PROFILE	D33	
PANEL PROFILE	PR324-10	
RAILS	MP646-57	
STILES	MP646-57	
APPLIED MOLDING	N/A	

CONSTRUCTION

MITERED CORNER
3/8-INCH THICK WOOD CENTER PANEL
3/4-INCH THICK STILES AND RAILS
3-INCH WIDE STILE AND RAILS

EDGE TREATMENTS

ADDITIONAL EDGES AVAILABLE

WOOD SPECIES

PLEASE SEE CHARTS ON PAGES 3-02 thru 3-04

DOOR

OUTSIDE EDGE PROFILE	D33	
PANEL PROFILE	PR324-10	
RAILS	MP646-76	
STILES	MP646-76	
APPLIED MOLDING	N/A	

CENTER PANEL

SOLID WOOD CENTER PANEL
MDF IN PAINTED FINISHES

FINISHES

PLEASE SEE CHARTS ON PAGES 3-04 thru 3-06

OPTIONS

WAINSCOT NOT AVAILABLE
FRAME DOORS AVAILABLE

MINIMUM REQUIREMENTS

DOOR	9" X 9"
DRAWER SLAB	N/A
DRAWER 3-PIECE	N/A
DRAWER 5-PIECE	8" X 6 3/4"
DRAWER 5/4 STATESMAN	N/A

BROOKLYN

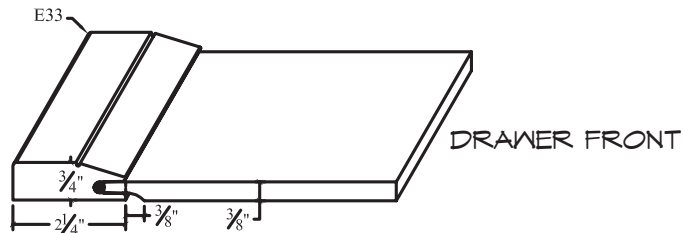

DRAWER FRONT

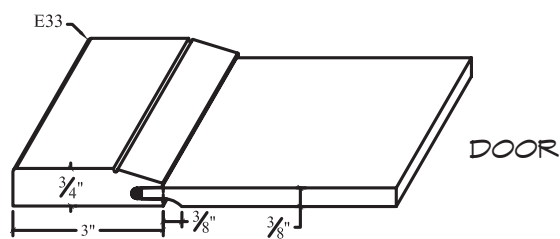

DOOR

DRAWER FRONT OPTIONS

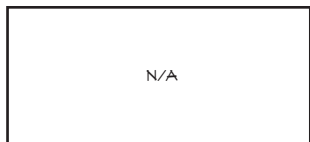

SLAB [UPCHARGE]

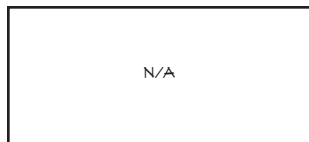

3-PIECE [STANDARD]

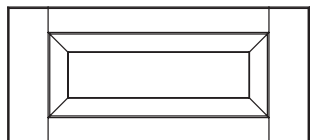

5-PIECE [UPCHARGE]



5/4 STATESMAN [UPCHARGE]

DRAWER FRONT

OUTSIDE EDGE PROFILE	D33	
PANEL PROFILE	PR324-10	
RAILS	MP646-57	
STILES	MP646-76	
APPLIED MOULDING		

CONSTRUCTION

3/8-INCH THICK WOOD CENTER PANEL
3/4-INCH THICK WOOD STILES AND RAILS
3-INCH WIDE STILE AND RAILS

FRONT WILL ACCEPT DOOR ADJUSTERS

CENTER PANEL

SOLID WOOD CENTER PANEL
MDF IN PAINTED FINISHES

OPTIONS

FULL OVERLAY 1/4" REVEAL TOP

EDGE TREATMENTS

WOOD SPECIES

PLEASE SEE CHARTS ON PAGE 3-02 thru 3-04

FINISHES

PLEASE SEE CHARTS ON PAGES 3-04 thru 3-06

MINIMUM REQUIREMENTS

DOOR

OUTSIDE EDGE PROFILE	D33	
PANEL PROFILE	PR324-10	
RAILS	MP678-76	
STILES	MP678-76	
APPLIED MOULDING		

4-12 Elite series cambridge doorstyle

CAMBRIDGE

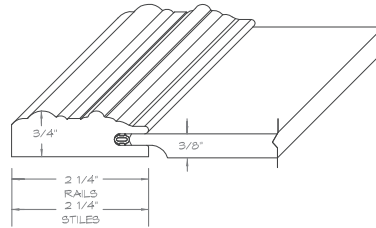

DRAWER
FRONT

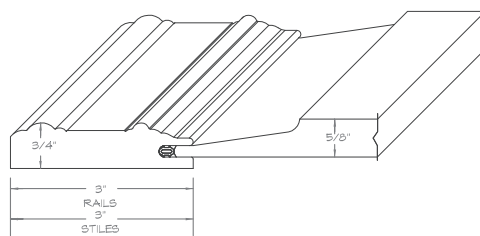

DOOR

DRAWER FRONT OPTIONS



N/A

SLAB



N/A

3-PIECE [UPCHARGE]

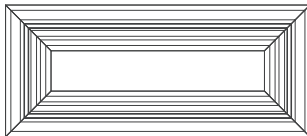



5-PIECE [STANDARD]



N/A

5/4 STATESMEN [UPCHARGE]

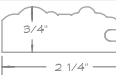
DRAWER FRONT

OUTSIDE EDGE PROFILE	N/A	N/A
PANEL PROFILE	PR324-10	
RAILS	MP102-57	
STILES	MP102-57	
APPLIED MOLDING	N/A	

CONSTRUCTION



MITERED CORNER
5/8-INCH THICK RAISED CENTER PANEL
3/4-INCH THICK STILES AND RAILS
3-INCH WIDE STILE AND RAILS

EDGE TREATMENTS

WOOD SPECIES

PLEASE SEE CHARTS ON PAGES 3-02 thru 3-04

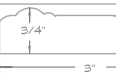
DOOR

OUTSIDE EDGE PROFILE	N/A	N/A
PANEL PROFILE	PR302	
RAILS	MP102-76	
STILES	MP102-76	
APPLIED MOLDING	N/A	

CENTER PANEL

SOLID WOOD CENTER PANEL
MDF IN PAINTED FINISHES

FINISHES

PLEASE SEE CHARTS ON PAGES 3-04 thru 3-06

OPTIONS

WAINSCOT NOT AVAILABLE
FRAME DOORS AVAILABLE

MINIMUM REQUIREMENTS

DOOR	11" X 11"
DRAWER SLAB	N/A
DRAWER 3-PIECE	N/A
DRAWER 5-PIECE	8" X 6 3/4"
DRAWER 5/4 STATESMAN	N/A

CLAYTON-33

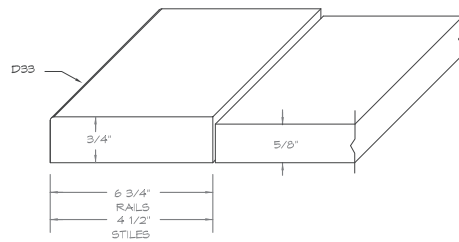

DRAWER FRONT
[UPCHARGE SHOWN]

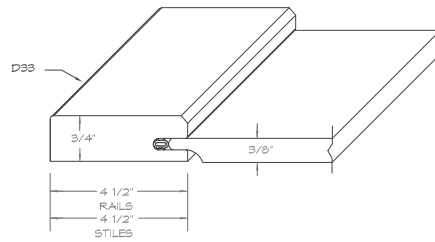

DOOR

DRAWER FRONT OPTIONS



SLAB [STANDARD]

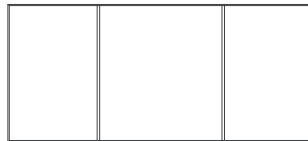

3-PIECE [UPCHARGE]



5-PIECE [UPCHARGE]



5/4 STATESMEN [UPCHARGE]

DRAWER FRONT

OUTSIDE EDGE PROFILE	D33	
PANEL PROFILE	N/A	
RAILS		
STILES		
APPLIED MOLDING	N/A	

CONSTRUCTION

MORTISE AND TENON JOINTS
3/8-INCH THICK WOOD CENTER PANEL
3/4-INCH THICK STILES
5/8-INCH THICK RAILS
4 1/2-INCH WIDE STILE AND RAILS

CENTER PANEL

SOLID WOOD CENTER PANEL
MDF IN PAINTED FINISHES

OPTIONS

WAINSCOT AVAILABLE
FRAME DOORS AVAILABLE

EDGE TREATMENTS

WOOD SPECIES

PLEASE SEE CHARTS ON PAGES 3-02 thru 3-04

FINISHES

PLEASE SEE CHARTS ON PAGES 3-04 thru 3-06

MINIMUM REQUIREMENTS

DOOR 12" X 12"
DRAWER SLAB N/A
DRAWER 3-PIECE 9" X 6 3/4"
DRAWER 5-PIECE N/A
DRAWER 5/4 STATESMAN N/A

DOOR

OUTSIDE EDGE PROFILE	D33	
PANEL PROFILE	PR324-10	
RAILS	SR100	
STILES	SR111	
APPLIED MOLDING	N/A	

4-14 Elite series cologne doorstyle

COLOGNE

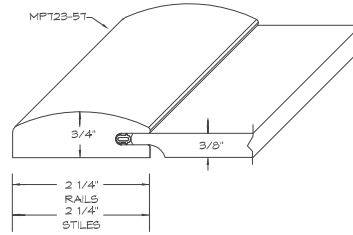

DRAWER FRONT

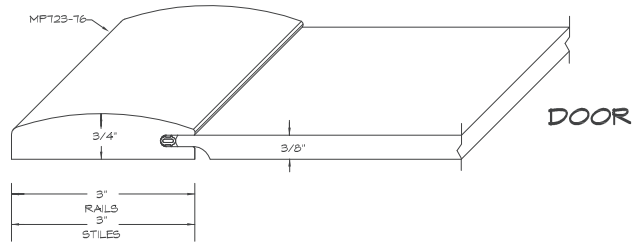

DOOR

DRAWER FRONT OPTIONS



SLAB



3-PIECE [UPCHARGE]

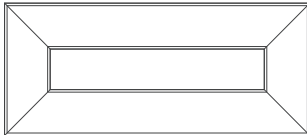

5-PIECE (STANDARD)



5/4 STATESMEN [UPCHARGE]

DRAWER FRONT

OUTSIDE EDGE PROFILE	N/A	
PANEL PROFILE	FR324-10	
RAILS	MPT23-5T	
STILES	MPT23-5T	
APPLIED MOLDING	N/A	

CONSTRUCTION

MITERED CORNER
3/8-INCH THICK WOOD CENTER PANEL
3/4-INCH THICK STILES AND RAILS
3-INCH WIDE STILES AND RAILS

CENTER PANEL

SOLID WOOD CENTER PANEL
MDF IN PAINTED FINISHES

OPTIONS

WAINSCOT NOT AVAILABLE
FRAME DOORS AVAILABLE

EDGE TREATMENTS

WOOD SPECIES

PLEASE SEE CHARTS ON PAGES 3-02 thru 3-04

FINISHES

PLEASE SEE CHARTS ON PAGES 3-04 thru 3-06

MINIMUM REQUIREMENTS

DOOR 9" X 9"
DRAWER SLAB N/A
DRAWER 3-PIECE N/A
DRAWER 5-PIECE 9" X 6 3/4"
DRAWER 5/4 STATESMAN N/A

DOOR

OUTSIDE EDGE PROFILE	N/A	
PANEL PROFILE	FR324-10	
RAILS	MPT23-T6	
STILES	MPT23-T6	
APPLIED MOLDING	N/A	

CONRAD-33

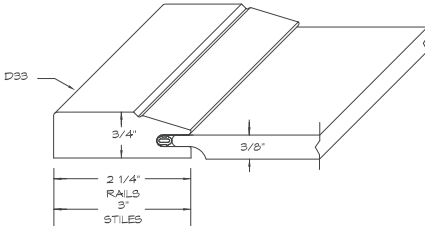

DRAWER FRONT
[UPCHARGE SHOWN]

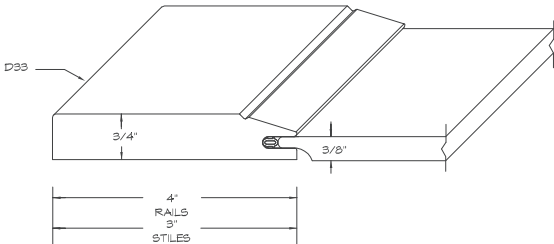

DOOR

DRAWER FRONT OPTIONS



SLAB [STANDARD]



3-PIECE [UPCHARGE]

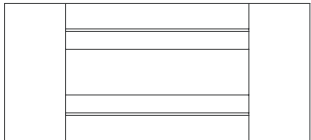

5-PIECE [UPCHARGE]



5/4 STATESMEN [UPCHARGE]

DRAWER FRONT

OUTSIDE EDGE PROFILE	D33	
PANEL PROFILE	PR324-10	
RAILS	MP643-57	
STILES	SR100	
APPLIED MOLDING	N/A	

CONSTRUCTION

MORTISE AND TENON JOINTS
3/8-INCH THICK WOOD CENTER PANEL
3/4-INCH THICK STILES AND RAILS
4-INCH WIDE RAILS
3-INCH WIDE STILES

EDGE TREATMENTS

ADDITIONAL EDGES AVAILABLE

WOOD SPECIES

PLEASE SEE CHARTS ON PAGES 3-02 thru 3-04

CENTER PANEL

SOLID WOOD CENTER PANEL
MDF IN PAINTED FINISHES

FINISHES

PLEASE SEE CHARTS ON PAGES 3-04 thru 3-06

OPTIONS

MAINSICOAT AVAILABLE
FRAME DOORS AVAILABLE

MINIMUM REQUIREMENTS

DOOR 9" X 11"
DRAWER SLAB 9" X 6 3/4"
DRAWER 3-PIECE 9" X 6 3/4"
DRAWER 5-PIECE 9" X 6 3/4"
DRAWER 5/4 STATESMAN N/A

DOOR

OUTSIDE EDGE PROFILE	D33	
PANEL PROFILE	PR324-10	
RAILS	MP643-102	
STILES	SR100	
APPLIED MOLDING	N/A	

4-16 Elite series cresta [french miter] doorstyle

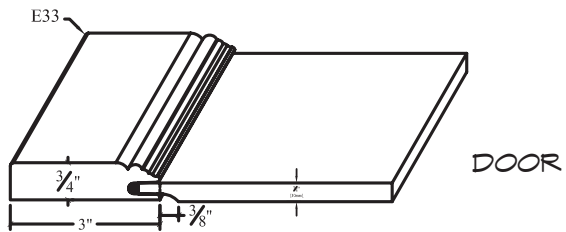
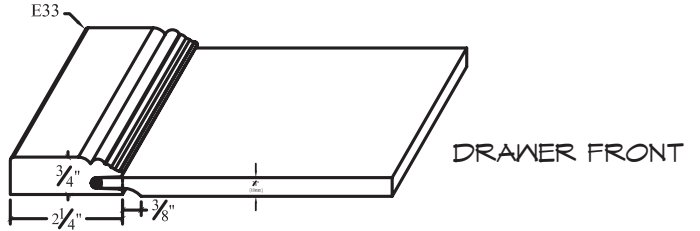

DRAWER FRONT OPTIONS



SLAB [UPCHARGE]

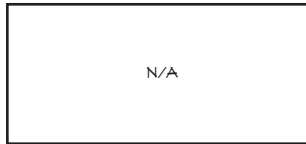

3-PIECE [STANDARD]

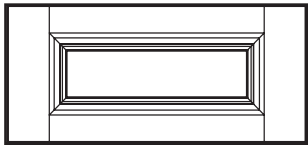

5-PIECE [UPCHARGE]



5/4 STATESMAN [UPCHARGE]

DRAWER FRONT

OUTSIDE EDGE PROFILE	D33	
PANEL PROFILE	PR324-10	
RAILS	MP681-57	
STILES	MP681-76	
APPLIED MOULDING		

CONSTRUCTION

3/8-INCH THICK WOOD CENTER PANEL
3/4-INCH THICK WOOD STILES AND RAILS
3-INCH WIDE STILE AND RAILS

FRONT WILL ACCEPT DOOR ADJUSTERS

CENTER PANEL

SOLID WOOD CENTER PANEL
MDF IN PAINTED FINISHES

OPTIONS

FULL OVERLAY 1/4" REVEAL TOP

EDGE TREATMENTS

WOOD SPECIES

PLEASE SEE CHARTS ON PAGES 3-02 thru 3-04

FINISHES

PLEASE SEE CHARTS ON PAGES 3-04 thru 3-06

MINIMUM REQUIREMENTS

DOOR

OUTSIDE EDGE PROFILE	D33	
PANEL PROFILE	PR324-10	
RAILS	MP681-76	
STILES	MP681-76	
APPLIED MOULDING		

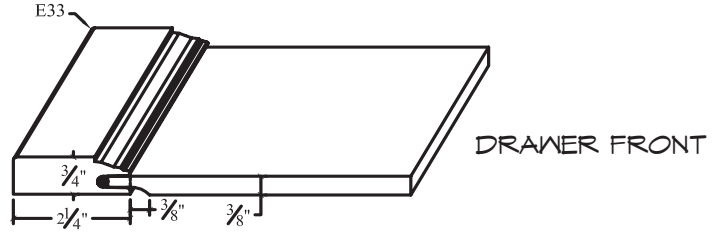

DRAWER FRONT

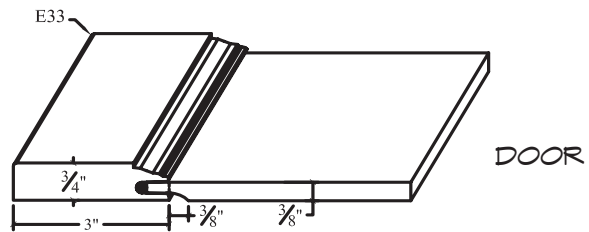

DOOR

DRAWER FRONT OPTIONS



SLAB [UPCHARGE]

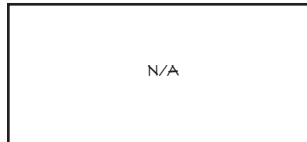

3-PIECE [UPCHARGE]

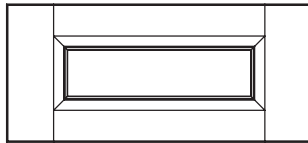

5-PIECE [STANDARD]



5/4 STATESMAN [UPCHARGE]

DRAWER FRONT

OUTSIDE EDGE PROFILE	D33	
PANEL PROFILE	PR324-10	
RAILS	MP668-57	
STILES	MP668-76	
APPLIED MOULDING		

CONSTRUCTION

3/8-INCH THICK WOOD CENTER PANEL
3/4-INCH THICK WOOD STILES AND RAILS
3-INCH WIDE STILE AND RAILS

FRONT WILL ACCEPT DOOR ADJUSTERS

CENTER PANEL

SOLID WOOD CENTER PANEL
MDF IN PAINTED FINISHES

OPTIONS

FULL OVERLAY 1/4" REVEAL TOP

EDGE TREATMENTS

WOOD SPECIES

PLEASE SEE CHARTS ON PAGES 3-02 thru 3-04

FINISHES

PLEASE SEE CHARTS ON PAGES 3-04 thru 3-06.
NATURE'S OWN IS STANDARD.

MINIMUM REQUIREMENTS

DOOR

OUTSIDE EDGE PROFILE	D33	
PANEL PROFILE	PR324-10	
RAILS	MP681-76	
STILES	MP681-76	
APPLIED MOULDING		

4-18 Elite series holston doorstyle

HOLSTON

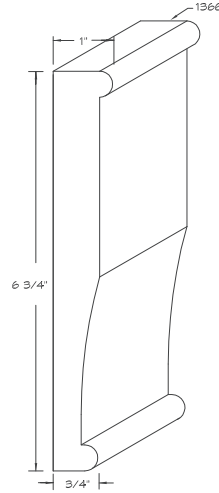

DRAWER FRONT
[UPCHARGE SHOWN]

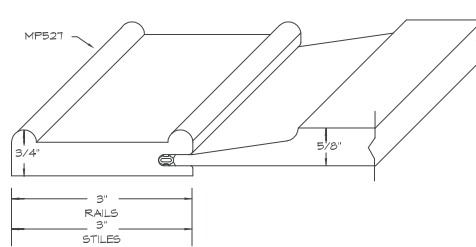

DOOR

DRAWER FRONT OPTIONS

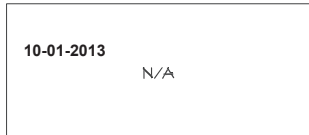

SLAB



3-PIECE [UPCHARGE]



5-PIECE [STANDARD]

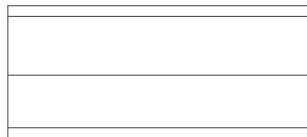

5/4 STATESMEN [UPCHARGE]

DRAWER FRONT

OUTSIDE EDGE PROFILE	N/A	
DRAWER STYLE	1366	
PANEL PROFILE	N/A	
RAILS	N/A	
STILES	N/A	
APPLIED MOLDING	N/A	

CONSTRUCTION

MITERED CORNER
5/8-INCH RAISED CENTER PANEL
3/4-INCH THICK STILES AND RAILS
3- INCH WIDE STILE AND RAILS
FIVE-PIECE DRAWER FRONT:
2 1/4- INCH WIDE RAILS
2 1/4- INCH WIDE STILES

CENTER PANEL

SOLID WOOD CENTER PANEL
MDF IN PAINTED FINISHES

OPTIONS

WAINSCOT NOT AVAILABLE
FRAME DOORS AVAILABLE

EDGE TREATMENTS

WOOD SPECIES

PLEASE SEE CHARTS ON PAGES 3-02 thru 3-04

FINISHES

PLEASE SEE CHARTS ON PAGES 3-04 thru 3-06

MINIMUM REQUIREMENTS

DOOR 12" X 12"
DRAWER SLAB N/A
DRAWER 3-PIECE N/A
DRAWER 5-PIECE 12" X 6 3/4"
DRAWER 5/4 STATESMAN 9" X 6 3/4"

DOOR

OUTSIDE EDGE PROFILE	N/A	
PANEL PROFILE	PR229	
RAILS	MPT21-76	
STILES	MPT21-76	
APPLIED MOLDING	N/A	

HOUGHTON-33

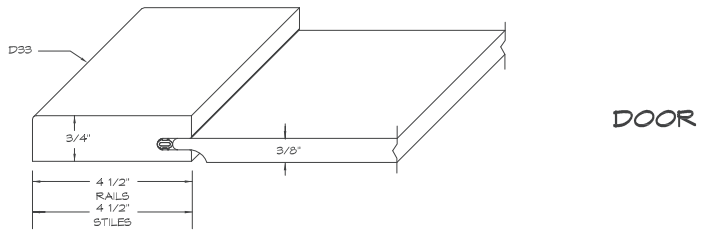
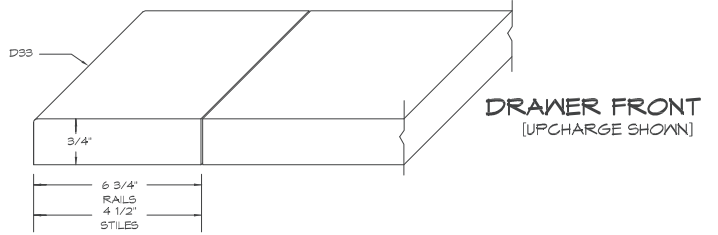

DRAWER FRONT OPTIONS



SLAB [STANDARD]



3-PIECE [UPCHARGE]



5-PIECE [UPCHARGE]



5/4 STATESMEN [UPCHARGE]

CONSTRUCTION

MORTISE AND TENON JOINTS
3/8-INCH THICK WOOD CENTER PANEL
3/4-INCH THICK STILES AND RAILS
4 1/2-INCH WIDE STILE AND RAILS

CENTER PANEL

SOLID WOOD CENTER PANEL
MDF IN PAINTED FINISHES

OPTIONS

MAINSICOAT AVAILABLE
FRAME DOORS AVAILABLE

EDGE TREATMENTS

ADDITIONAL EDGES AVAILABLE

WOOD SPECIES

PLEASE SEE CHARTS ON PAGES 3-02 thru 3-04

FINISHES

PLEASE SEE CHARTS ON PAGES 3-04 thru 3-06

MINIMUM REQUIREMENTS

DOOR 11 1/2" X 11 1/2"
DRAWER SLAB 9" X 6 3/4"
DRAWER 3-PIECE 12" X 6 3/4"
DRAWER 5-PIECE N/A
DRAWER 5/4 STATESMAN N/A

DRAWER FRONT

OUTSIDE EDGE PROFILE	D33	
PANEL PROFILE	N/A	
RAILS	SR100	
STILES	SR100	
APPLIED MOLDING	N/A	

DOOR

OUTSIDE EDGE PROFILE	D33	
PANEL PROFILE	PR324-10	
RAILS	SR100	
STILES	SR100	
APPLIED MOLDING	N/A	

4-20 Elite series juilliard doorstyle

JUILLIARD

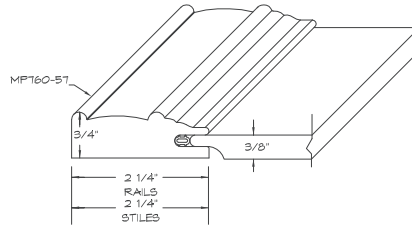

DRAWER FRONT

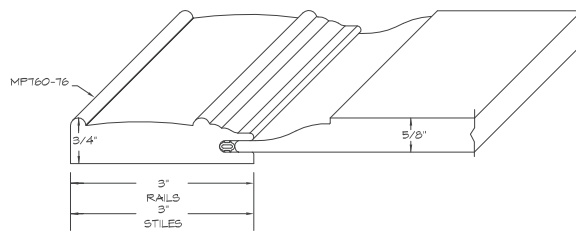

DOOR

DRAWER FRONT OPTIONS



N/A

SLAB



N/A

3-PIECE [UPCHARGE]

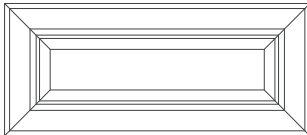

5-PIECE [STANDARD]



N/A

5/4 STATESMEN [UPCHARGE]

DRAWER FRONT

OUTSIDE EDGE PROFILE	N/A	
PANEL PROFILE	PR324-10	
RAILS	MP160-57	
STILES	MP160-57	
APPLIED MOLDING	N/A	

CONSTRUCTION

MITERED CORNER
5/8-INCH THICK RAISED CENTER PANEL
3/4-INCH THICK STILES AND RAILS
3-INCH WIDE STILE AND RAILS

CENTER PANEL

SOLID WOOD CENTER PANEL
MDF IN PAINTED FINISHES

OPTIONS

WAINSCOAT NOT AVAILABLE
FRAME DOORS AVAILABLE

EDGE TREATMENTS

WOOD SPECIES

PLEASE SEE CHARTS ON PAGES 3-02 thru 3-04

FINISHES

PLEASE SEE CHARTS ON PAGES 3-04 thru 3-06

MINIMUM REQUIREMENTS

DOOR 11" X 11"
DRAWER SLAB N/A
DRAWER 3-PIECE N/A
DRAWER 5-PIECE 9" X 6 3/4"
DRAWER 5/4 STATESMAN N/A

DOOR

OUTSIDE EDGE PROFILE	N/A	
PANEL PROFILE	PR303-32	
RAILS	MP160-76	
STILES	MP160-76	
APPLIED MOLDING	N/A	

Elite series 4-21 manor [french miter] doorstyle

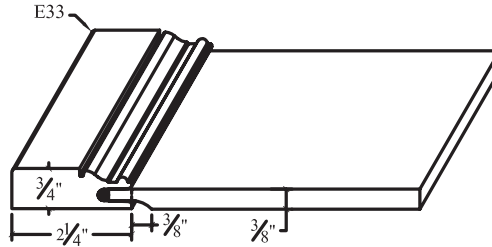

DRAWER FRONT

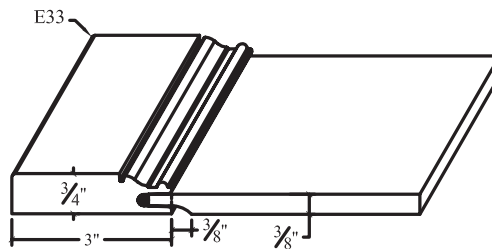

DOOR

DRAWER FRONT OPTIONS



SLAB [UPCHARGE]

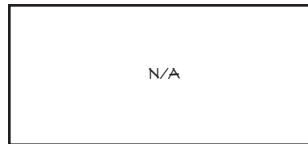

3-PIECE [UPCHARGE]

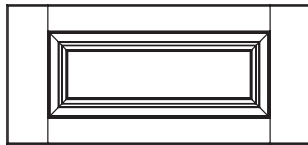

5-PIECE [STANDARD]

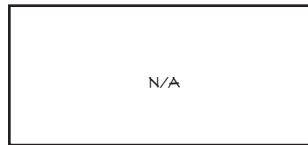

5/4 STATESMAN [UPCHARGE]

DRAWER FRONT

OUTSIDE EDGE PROFILE	D33	
PANEL PROFILE	PR324-10	
RAILS	MP604-57	
STILES	MP604-76	
APPLIED MOULDING		

CONSTRUCTION

3/8-INCH THICK WOOD CENTER PANEL
3/4-INCH THICK WOOD STILES AND RAILS
3-INCH WIDE STILE AND RAILS

FRONT WILL ACCEPT DOOR ADJUSTERS

CENTER PANEL

SOLID WOOD CENTER PANEL
MDF IN PAINTED FINISHES

OPTIONS

FULL OVERLAY 1/4" REVEAL TOP

EDGE TREATMENTS

WOOD SPECIES

PLEASE SEE CHARTS ON PAGES 3-02 thru 3-04

FINISHES

PLEASE SEE CHARTS ON PAGES 3-04 thru 3-06
NATURE'S OWN IS STANDARD.

MINIMUM REQUIREMENTS

DOOR

OUTSIDE EDGE PROFILE	D33	
PANEL PROFILE	PR324-10	
RAILS	MP604-76	
STILES	MP604-76	
APPLIED MOULDING		

4-22 Elite series meridian doorstyle

MERIDIAN-33

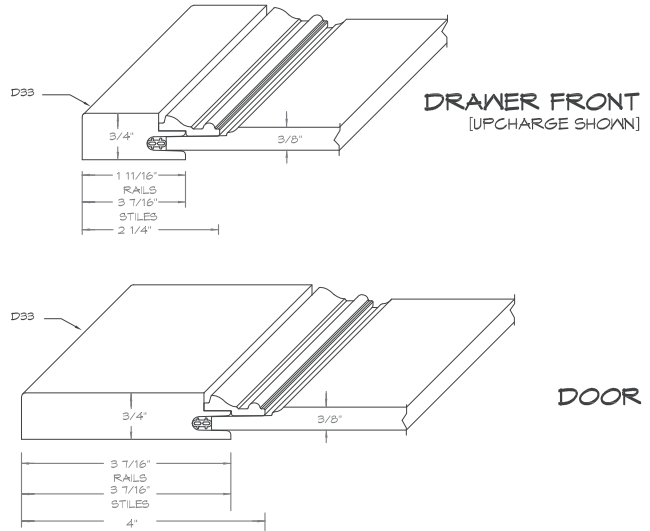

DRAWER FRONT OPTIONS



SLAB [STANDARD]

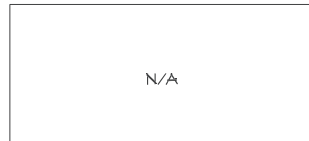

3-PIECE [UPCHARGE]

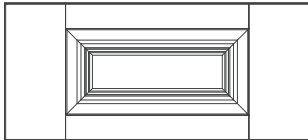

5-PIECE [UPCHARGE]



5/4 STATESMEN [UPCHARGE]

DRAWER FRONT

OUTSIDE EDGE PROFILE	D33	
PANEL PROFILE	PR320-22NC	
RAILS	SR136	
STILES	SR136	
APPLIED MOLDING	1280	

CONSTRUCTION

MORTISE AND TENON JOINTS
 3/8-INCH THICK RAISED CENTER PANEL
 3/4-INCH THICK STILES AND RAILS
 3 7/16-INCH WIDE STILES AND RAILS
 APPLIED MOLDING

CENTER PANEL

SOLID WOOD CENTER PANEL
 MDF IN PAINTED FINISHES

OPTIONS

MAINSOAT AVAILABLE
 FRAME DOORS AVAILABLE

EDGE TREATMENTS

ADDITIONAL EDGES AVAILABLE

WOOD SPECIES

PLEASE SEE CHARTS ON PAGES 3-02 thru 3-04

FINISHES

PLEASE SEE CHARTS ON PAGES 3-04 thru 3-06

MINIMUM REQUIREMENTS

DOOR 11 1/2" X 11 1/2"
 DRAWER SLAB 8" X 6 3/4"
 DRAWER 3-PIECE N/A
 DRAWER 5-PIECE 11 1/2" X 6 3/4"
 DRAWER 5/4 STATESMAN N/A

DOOR

OUTSIDE EDGE PROFILE	D33	
PANEL PROFILE	PR320-22NC	
RAILS	SR136	
STILES	SR136	
APPLIED MOLDING	1280	

MONTANA-41

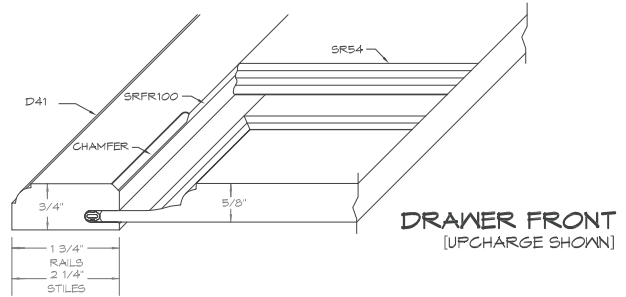

DRAWER FRONT
[UPCHARGE SHOWN]

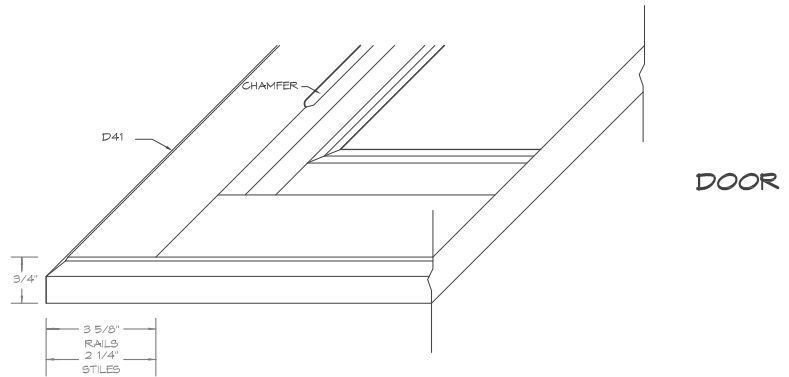

DOOR

DRAWER FRONT OPTIONS

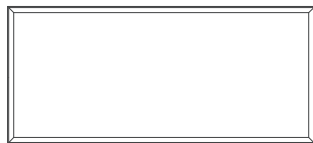

SLAB [STANDARD]

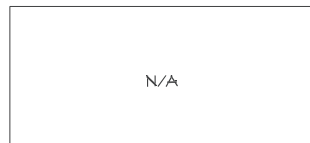

3-PIECE [UPCHARGE]

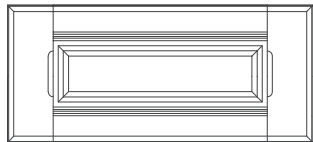

5-PIECE [UPCHARGE]



5/4 STATESMEN [UPCHARGE]

DRAWER FRONT

OUTSIDE EDGE PROFILE	D41	
PANEL PROFILE	PR305-19	
RAILS	SR54	
STILES	SR100	
APPLIED MOLDING	N/A	

CONSTRUCTION

MORTISE AND TENON JOINTS
5/8-INCH THICK RAISED CENTER PANEL
3/4-INCH THICK STILES AND RAILS
2 1/4-INCH WIDE STILES
3 5/8-INCH WIDE RAILS

CENTER PANEL

SOLID WOOD CENTER PANEL
MDF IN PAINTED FINISHES

OPTIONS

WAINSCOT AVAILABLE
FRAME DOORS AVAILABLE

EDGE TREATMENTS

ADDITIONAL EDGES AVAILABLE

WOOD SPECIES

PLEASE SEE CHARTS ON PAGES 3-02 thru 3-04

FINISHES

PLEASE SEE CHARTS ON PAGES 3-04 thru 3-06

MINIMUM REQUIREMENTS

DOOR 9 1/2" X 10 1/4"
DRAWER SLAB 8" X 6 3/4"
DRAWER 3-PIECE N/A
DRAWER 5-PIECE 9 1/2" X 6 3/4"
DRAWER 5/4 STATESMAN N/A

DOOR

OUTSIDE EDGE PROFILE	D41	
PANEL PROFILE	PR305-32	
RAILS	SR54	
STILES	SR100	
APPLIED MOLDING	N/A	

4-24 Elite series odessa doorstyle

ODESSA-38

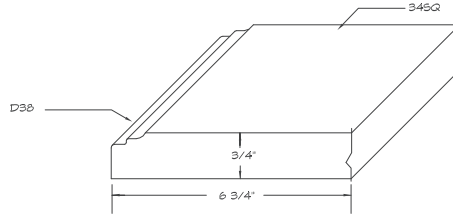

DRAWER FRONT

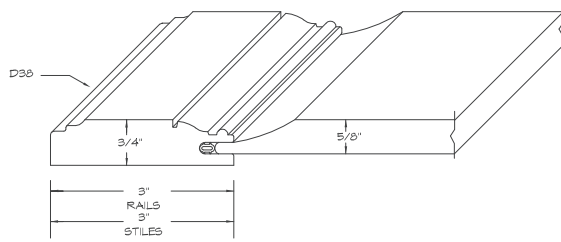

DOOR

DRAWER FRONT OPTIONS



SLAB [STANDARD]



3-PIECE [UPCHARGE]



5-PIECE [UPCHARGE]



5/4 STATESMEN [UPCHARGE]

DRAWER FRONT

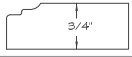
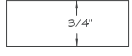
OUTSIDE EDGE PROFILE	D38	
DRAWER STYLE	345Q	
PANEL PROFILE	N/A	
RAILS	N/A	
STILES	N/A	
APPLIED MOLDING	N/A	

CONSTRUCTION

MITERED CORNER
5/8-INCH THICK RAISED CENTER PANEL
3/4-INCH THICK STILES AND RAILS
3-INCH WIDE STILES AND RAILS
FIVE-PIECE DRAWER FRONT:
2 1/4-INCH WIDE RAILS
2 1/4-INCH WIDE STILES

CENTER PANEL

SOLID WOOD CENTER PANEL
MDF IN PAINTED FINISHES

OPTIONS

WAINSCOT NOT AVAILABLE
FRAME DOORS AVAILABLE

EDGE TREATMENTS

ADDITIONAL EDGES AVAILABLE

WOOD SPECIES

PLEASE SEE CHARTS ON PAGES 3-02 thru 3-04



FINISHES

PLEASE SEE CHARTS ON PAGES 3-04 thru 3-06

MINIMUM REQUIREMENTS

DOOR	10" X 10"
DRAWER SLAB	8" X 6 3/4"
DRAWER 3-PIECE	N/A
DRAWER 5-PIECE	10" X 6 3/4"
DRAWER 5/4 STATESMAN	N/A

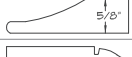
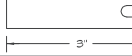
DOOR

OUTSIDE EDGE PROFILE	D38	
PANEL PROFILE	PR215	
RAILS	MP604-76	
STILES	MP604-76	
APPLIED MOLDING	N/A	

Elite series 4-25 plaza doorstyle

PLAZA

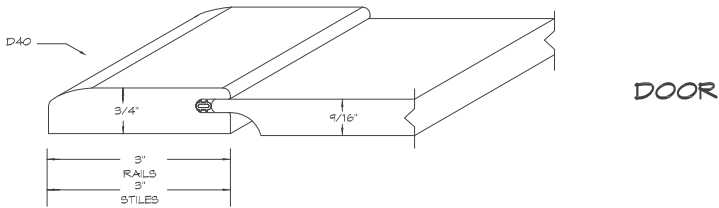
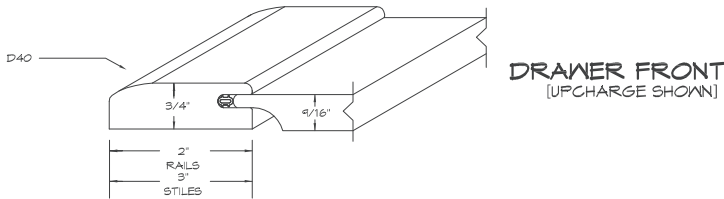

DRAWER FRONT OPTIONS



SLAB [STANDARD]



3-PIECE [UPCHARGE]

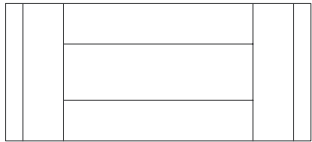

5-PIECE [UPCHARGE]



5/4 STATESMEN [UPCHARGE]

N/A

DRAWER FRONT

OUTSIDE EDGE PROFILE	D40	
OUTSIDE EDGE PROFILE	D57	
PANEL PROFILE	FR324-10	
RAILS	SR118-D57	
STILES	SR118-D40	
APPLIED MOLDING	N/A	

CONSTRUCTION

MORTISE AND TENON JOINTS
9/16-INCH THICK WOOD CENTER PANEL
3/4-INCH THICK STILES AND RAILS
3-INCH WIDE STILES AND RAILS

EDGE TREATMENTS

N/A

WOOD SPECIES

PLEASE SEE CHARTS ON PAGES 3-02 thru 3-04

CENTER PANEL

SOLID WOOD CENTER PANEL
MDF IN PAINTED FINISHES

FINISHES

PLEASE SEE CHARTS ON PAGES 3-04 thru 3-06

OPTIONS

MAINSICOAT AVAILABLE
FRAME DOORS AVAILABLE

MINIMUM REQUIREMENTS

DOOR 9" X 9"
DRAWER SLAB 9" X 6 3/4"
DRAWER 3-PIECE 9" X 6 3/4"
DRAWER 5-PIECE 9" X 6 3/4"
DRAWER 5/4 STATESMAN N/A

DOOR

OUTSIDE EDGE PROFILE	D40	
OUTSIDE EDGE PROFILE	D57	
PANEL PROFILE	FR324-10	
RAILS	SR118-D57	
STILES	SR118-D40	
APPLIED MOLDING	N/A	

4-26 Elite series
rio verde [french miter] doorstyle

RIO VERDE

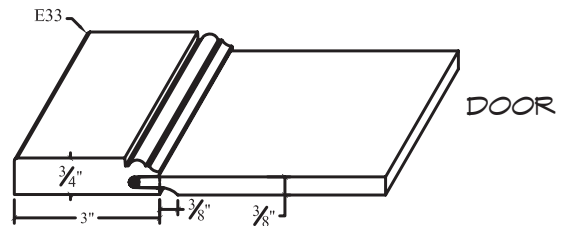
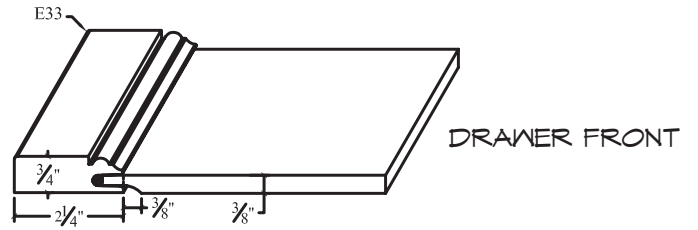
DRAWER FRONT OPTIONS

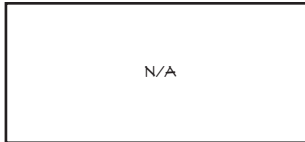

SLAB [UPCHARGE]



3-PIECE [UPCHARGE]

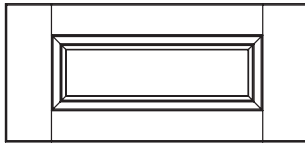



5-PIECE [STANDARD]

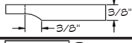

5/4 STATESMAN [UPCHARGE]

DRAWER FRONT

OUTSIDE EDGE PROFILE	D33	
PANEL PROFILE	PR324-10	
RAILS	MP659-57	
STILES	MP659-76	
APPLIED MOULDING		

CONSTRUCTION

3/8-INCH THICK WOOD CENTER PANEL
3/4-INCH THICK WOOD STILES AND RAILS
3-INCH WIDE STILE AND RAILS

FRONT WILL ACCEPT DOOR ADJUSTERS

CENTER PANEL

SOLID WOOD CENTER PANEL
MDF IN PAINTED FINISHES

OPTIONS

FULL OVERLAY 1/4" REVEAL TOP

EDGE TREATMENTS

WOOD SPECIES



PLEASE SEE CHARTS ON PAGES 3-02 thru 3-04

FINISHES

PLEASE SEE CHARTS ON PAGES 3-04 thru 3-06

MINIMUM REQUIREMENTS

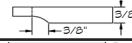
DOOR

OUTSIDE EDGE PROFILE	D33	
PANEL PROFILE	PR324-10	
RAILS	MP659-76	
STILES	MP659-76	
APPLIED MOULDING		

SCHAUMBURG-48

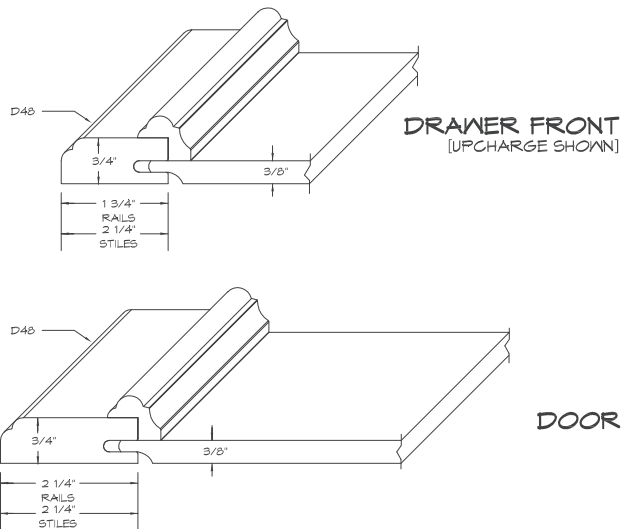

DRAWER FRONT OPTIONS



SLAB [STANDARD]



3-PIECE [UPCHARGE]

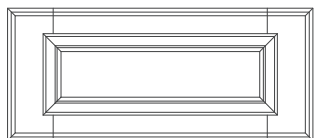

5-PIECE [UPCHARGE]



5/4 STATESMEN [UPCHARGE]

DRAWER FRONT

OUTSIDE EDGE PROFILE	D48	
PANEL PROFILE	PR324-10	
RAILS	SR100	
STILES	SR100	
APPLIED MOLDING	102	

CONSTRUCTION

MORTISE AND TENON JOINTS
3/8-INCH THICK WOOD CENTER PANEL
3/4-INCH THICK STILES AND RAILS
2 1/4-INCH WIDE STILES AND RAILS
APPLIED MOLDING

CENTER PANEL

SOLID WOOD CENTER PANEL
MDF IN PAINTED FINISHES

OPTIONS

MAINSICOAT AVAILABLE
FRAME DOORS AVAILABLE

EDGE TREATMENTS

ADDITIONAL EDGES AVAILABLE

WOOD SPECIES

PLEASE SEE CHARTS ON PAGES 3-02 thru 3-04

FINISHES

PLEASE SEE CHARTS ON PAGES 3-04 thru 3-06

MINIMUM REQUIREMENTS

DOOR	8" X 8"
DRAWER SLAB	8" X 6 3/4"
DRAWER 3-PIECE	N/A
DRAWER 5-PIECE	8" X 6 3/4"
DRAWER 5/4 STATESMAN	N/A

DOOR

OUTSIDE EDGE PROFILE	D48	
PANEL PROFILE	PR324-10	
RAILS	SR100	
STILES	SR100	
APPLIED MOLDING	102	

4-28 Elite series slater doorstyle

SLATER-33

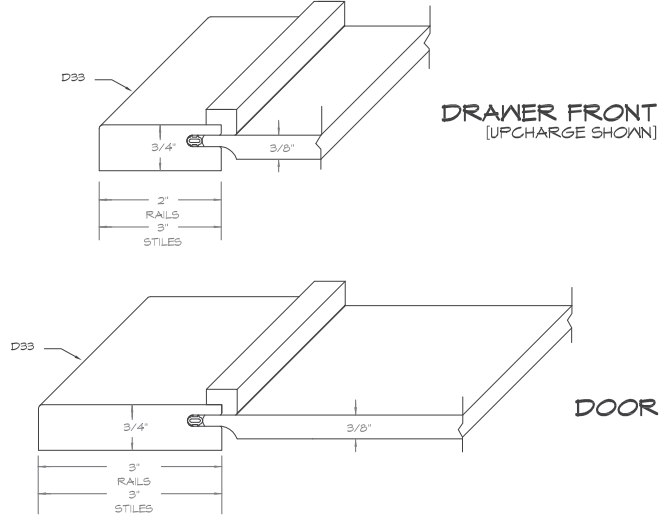

DRAWER FRONT OPTIONS



SLAB [STANDARD]



3-PIECE [UPCHARGE]

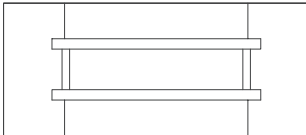

5-PIECE [UPCHARGE]



5/4 STATESMEN [UPCHARGE]

CONSTRUCTION

MORTISE AND TENON JOINTS
3/8-INCH THICK WOOD CENTER PANEL
3/4-INCH THICK STILES AND RAILS
3-INCH WIDE STILES AND RAILS
APPLIED MOLDING

CENTER PANEL

SOLID WOOD CENTER PANEL
MDF IN PAINTED FINISHES

OPTIONS

WAINSCOT AVAILABLE
FRAME DOORS AVAILABLE

EDGE TREATMENTS

ADDITIONAL EDGES AVAILABLE

WOOD SPECIES

PLEASE SEE CHARTS ON PAGES 3-02 thru 3-04

FINISHES

PLEASE SEE CHARTS ON PAGES 3-04 thru 3-06

MINIMUM REQUIREMENTS

DOOR 9" x 9"
DRAWER SLAB 8" x 6 3/4"
DRAWER 3-PIECE N/A
DRAWER 5-PIECE 9" x 6 3/4"
DRAWER 5/4 STATESMAN N/A

DRAWER FRONT

OUTSIDE EDGE PROFILE	D33	
PANEL PROFILE	PR324-10	
RAILS	SR104	
STILES	SR104	
APPLIED MOLDING	1174	
APPLIED MOLDING	1175	

DOOR

OUTSIDE EDGE PROFILE	D33	
PANEL PROFILE	PR324-10	
RAILS	SR104	
STILES	SR104	
APPLIED MOLDING	1174	
APPLIED MOLDING	1175	

VISION-33

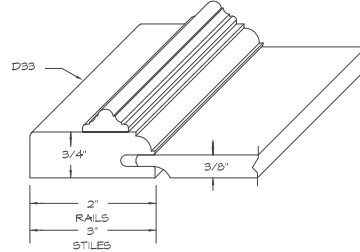

DRAWER FRONT
[UPCHARGE SHOWN]

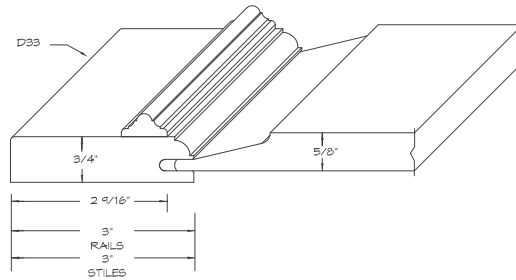

DOOR

DRAWER FRONT OPTIONS

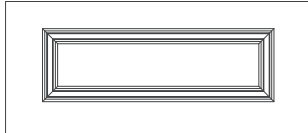

SLAB WITH APPLIED MOLDING
[STANDARD]



3-PIECE [UPCHARGE]

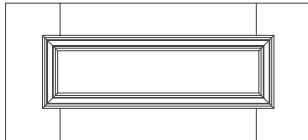

5-PIECE [UPCHARGE]



5/4 STATESMEN [UPCHARGE]

DRAWER FRONT

OUTSIDE EDGE PROFILE	D33	
DRAWER STYLE	34SQ	
PANEL PROFILE	FR324-10	
RAILS	SR105	
STILES	SR105	
APPLIED MOLDING	922	

CONSTRUCTION

MORTISE AND TENON JOINTS
5/8-INCH THICK RAISED CENTER PANEL
3/4-INCH THICK STILES AND RAILS
3-INCH WIDE STILES AND RAILS
APPLIED MOLDING

EDGE TREATMENTS

ADDITIONAL EDGES AVAILABLE

WOOD SPECIES

PLEASE SEE CHARTS ON PAGES 3-02 thru 3-04

CENTER PANEL

SOLID WOOD CENTER PANEL
MDF IN PAINTED FINISHES

FINISHES

PLEASE SEE CHARTS ON PAGES 3-04 thru 3-06

OPTIONS

MAINSICOAT AVAILABLE
FRAME DOORS AVAILABLE

MINIMUM REQUIREMENTS

DOOR 11" X 11"
DRAWER SLAB 8" X 6 3/4"
DRAWER 3-PIECE N/A
DRAWER 5-PIECE 9" X 6 3/4"
DRAWER 5/4 STATESMAN N/A

DOOR

OUTSIDE EDGE PROFILE	D33	
PANEL PROFILE	FR302-32	
RAILS	SR105	
STILES	SR105	
APPLIED MOLDING	922	

4-30 Elite series
notes

NOTES

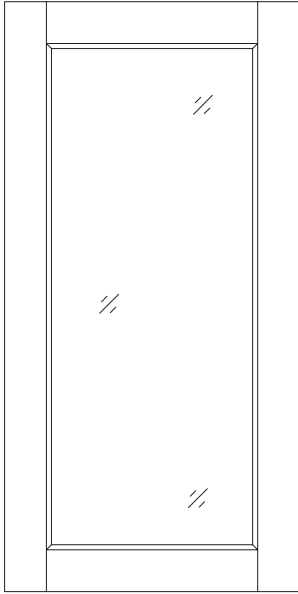

FRAME DOOR

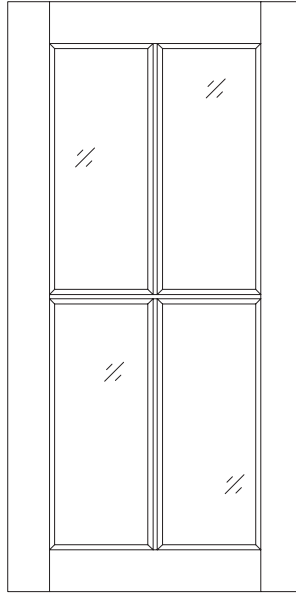

FRAME DOOR

4 LITES
 LP001

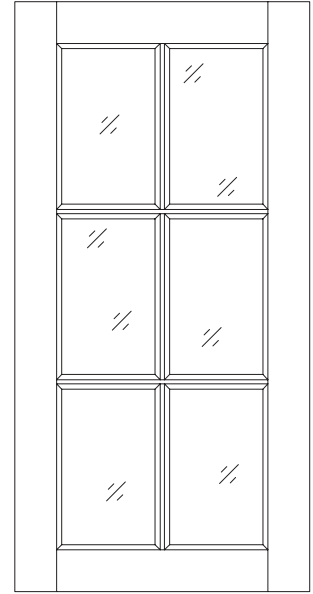

FRAME DOOR

6 LITES
 LP001

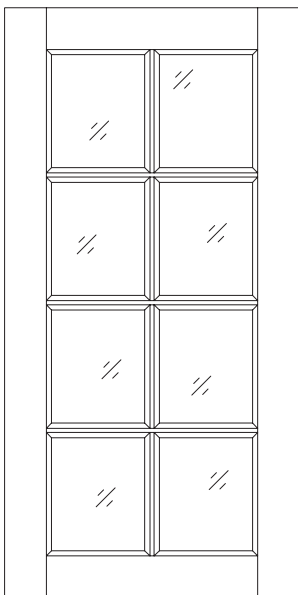

FRAME DOOR

8 LITES
 LP001

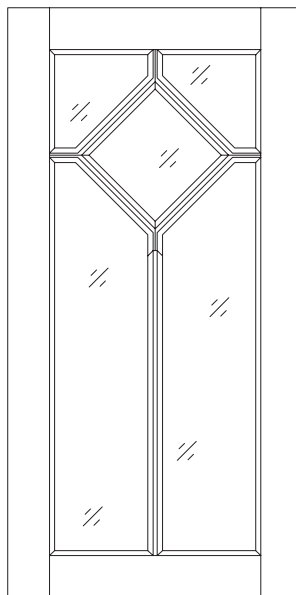

FRAME DOOR

5 LITES
 LP100

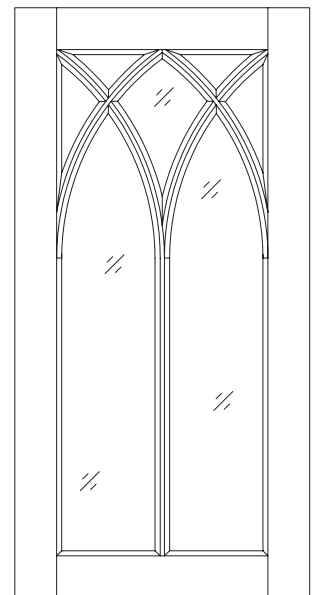

FRAME DOOR

7 LITES
 LP105

4-32 Elite series
arched mullion

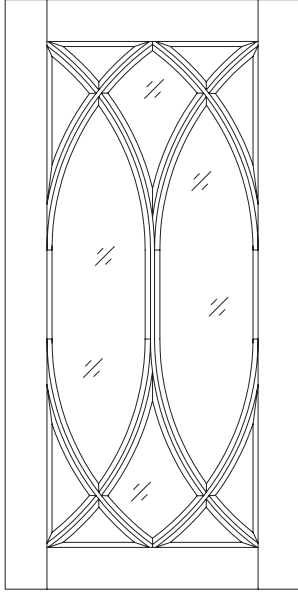

FRAME DOOR
12 LITES
LP105

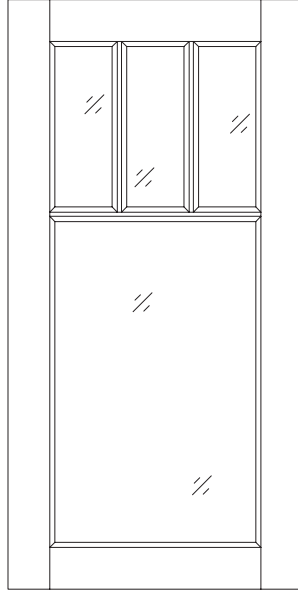

FRAME DOOR
4 LITES
LP109

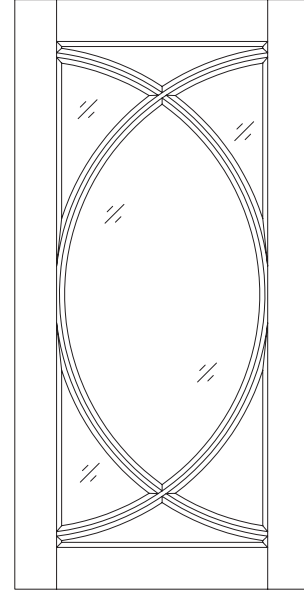

FRAME DOOR
7 LITES
LP112

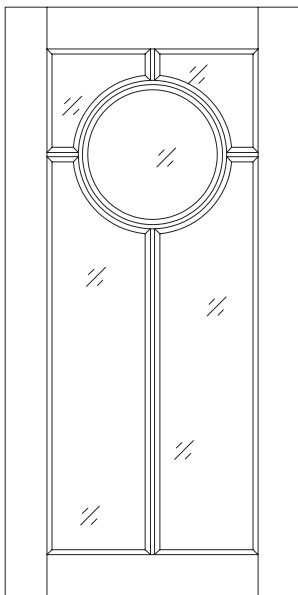

FRAME DOOR
5 LITES
LP113

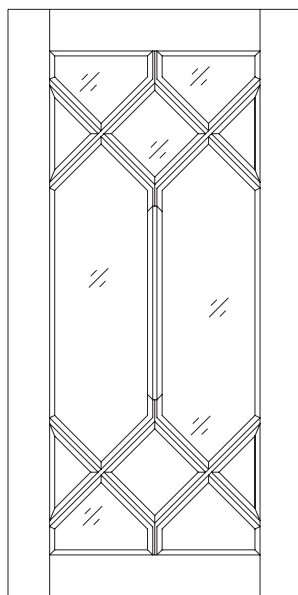

FRAME DOOR
12 LITES
LP115

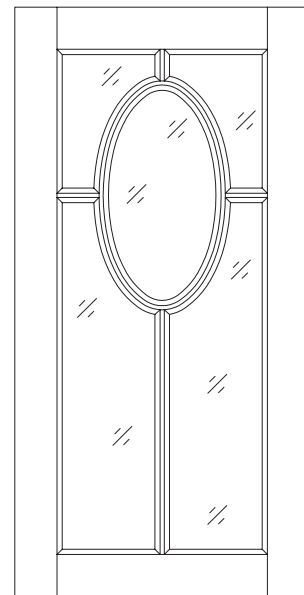

FRAME DOOR
5 LITES
LP116

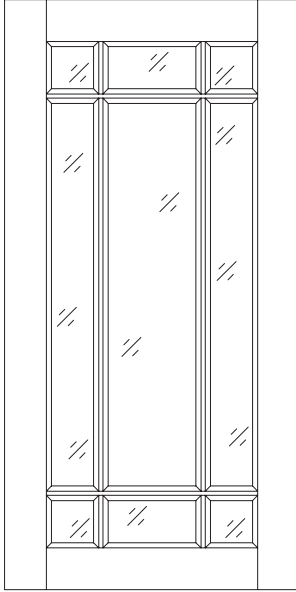

FRAME DOOR
 9 LITES
 LP118

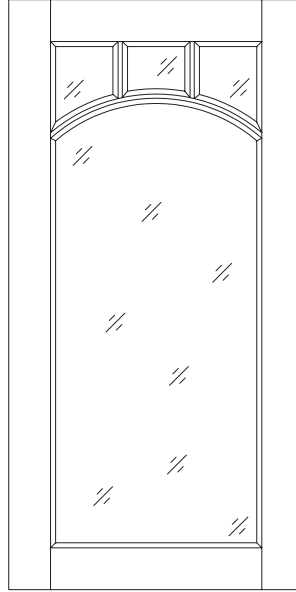

FRAME DOOR
 4 LITES
 LP121

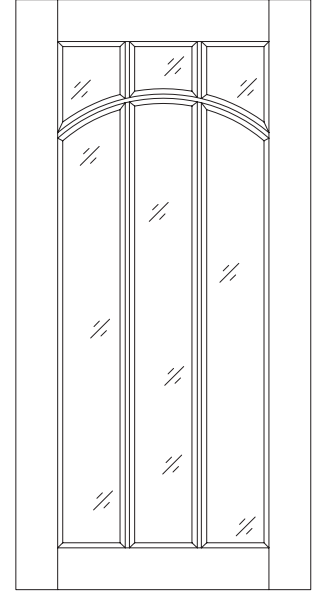

FRAME DOOR
 6 LITES
 LP122

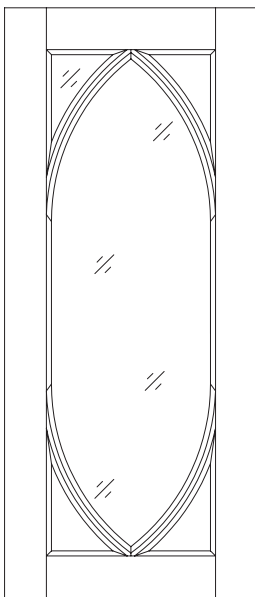

FRAME DOOR
 5 LITES
 LP125

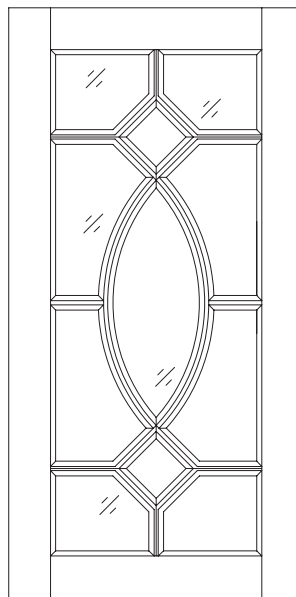

FRAME DOOR
 11 LITES
 LP126

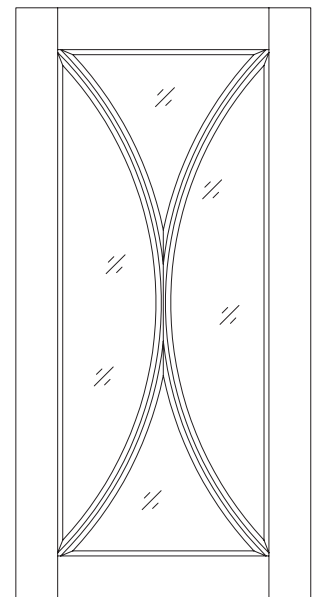

FRAME DOOR
 4 LITES
 LP127

4-34 Elite series mullion information



CONSTRUCTION

INSERT CAN BE 1/8" THICK
(NOT INCLUDED)
3/4" THICK STILES AND RAILS

CENTER PANEL

OPTIONS

EDGE TREATMENTS

WOOD SPECIES

MAPLE, PLAIN SLICED
RED OAK, PLAIN SLICED
ALDER, PLAIN SLICED
CHERRY, PLAIN SLICED
STEEMED BEECH
QUARTERED WHITE OAK
WALNUT, PLAIN SLICED
RUSTIC ALDER
RUSTIC CHERRY
RUSTIC WALNUT

FINISHES

PLEASE SEE CHARTS ON PAGES 3-04 thru 3-06

MINIMUM REQUIREMENTS

DOOR

12" X 12"
WITH 2 1/4" STILES
AND RAILS

CORNER LITES

2" X 2"
(SPECIFY HEIGHT
AND WIDTH OF
CORNER LITES)