

**cabinet accessories**

11-02 cabinet accessories  
notes

# NOTES

SHELVES

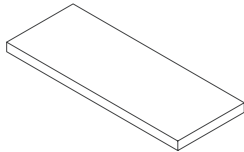

ABBREVIATION  
N/A

STANDARD BIRCH OR  
HARDROCK MAPLE MELAMINE  
WALL DEPTH  
BASE DEPTH

MVI SHELF  
(STAINED TO MATCH EXTERIOR)  
WALL DEPTH  
BASE DEPTH

SHELF MOULDING OR  
SOLID STOCK NOSING  
MAY BE ADDED TO A  
FINISHED SHELF. PLEASE  
SPECIFY.

3" COLUMN

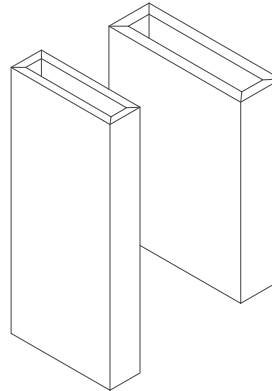

ABBREVIATION

WALL NCS  
BASE BCS  
TALL 12 7/8" (UP TO 96") TCS  
TALL 24 7/8" (UP TO 96")  
TALL 30 7/8" (UP TO 96")

36" BASE PENINSULA BCS-P

BOTH SIDES OF STRAIGHT COLUMN  
HAVE FLUSH, MITERED FINISHED ENDS.  
MELAMINE, ACRYLIC, AND FOIL WILL  
ALWAYS BE BUTT JOINTED, NOT  
MITERED.  
TALL AND BASE COLUMNS HAVE  
WIDE BOTTOM RAILS.

BASE DEPTHS  
ON-U DEPTH: 24 7/8"  
AMENITY DEPTH: 24"  
WALL DEPTHS  
ON-U DEPTH: 12 7/8"  
AMENITY DEPTH: 12"

MATCHING WOOD  
TOP

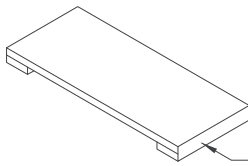

ABBREVIATION

MWT

THICKNESSES: 1, 1 1/4, OR 1 1/2"  
LENGTHS: UP TO 96"  
EDGES AVAILABLE: PLEASE CONSULT THE  
BUILD YOUR OWN MOULDING SECTION  
FINISHES AVAILABLE: OAK, MAPLE, CHERRY,  
ALDER, WALNUT, PAINT MAPLE, 1/4 SAWN OAK.

SPECIFY FINISHED ENDS OR OTHER  
CHARACTERISTICS. DRAWING REQUIRED FOR  
SPECIAL FEATURES.

MAXIMUM LENGTH IS 93" WITH NO JOINT.  
LONGER LENGTHS WILL HAVE A BUTT JOINT.

SPECIFY  
EDGE  
DETAIL



STANDARD

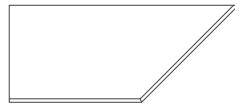

MITER



FINISH END



BUTT JOINT

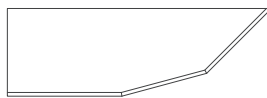

ANGLE CORNER



PENINSULA

3" FLUTED COLUMN

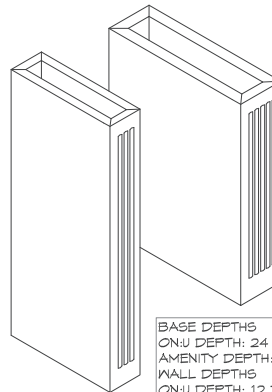

ABBREVIATION

WALL NCSF  
BASE BCSF  
TALL 12 7/8" (UP TO 96") TCSF  
TALL 24 7/8" (UP TO 96")  
TALL 30 7/8" (UP TO 96")

36" BASE PENINSULA BCSF-P

BOTH SIDES OF STRAIGHT COLUMN  
HAVE FLUSH, MITERED FINISHED ENDS.  
MELAMINE, ACRYLIC, AND FOIL WILL  
ALWAYS BE BUTT JOINTED, NOT  
MITERED.  
TALL AND BASE COLUMNS HAVE  
WIDE BOTTOM RAILS.

BASE DEPTHS  
ON-U DEPTH: 24 7/8"  
AMENITY DEPTH: 24"  
WALL DEPTHS  
ON-U DEPTH: 12 7/8"  
AMENITY DEPTH: 12"

3" COLUMN WITH  
INTEGRAL WAINSCOT  
END

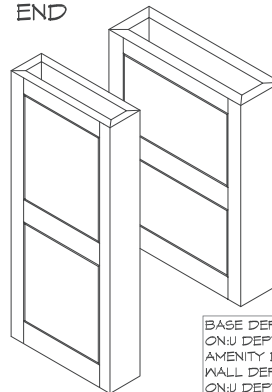

ABBREVIATION

WALL NCS-IWE-L/R  
BASE BCS-IWE-L/R  
TALLS  
12 7/8" (UP TO 96") TCS-IWE-L/R  
24 7/8" (UP TO 96")

36" BASE PENINSULA BCS-P-IWE-L/R

WAINSCOT END DOES NOT INCREASE  
WIDTH OF COLUMN.  
CENTER PANEL WILL ALIGN WITH  
DOOR ON FRONT OF CABINET.  
TALL AND BASE COLUMNS HAVE  
WIDE BOTTOM RAILS.  
INSET STYLING WILL HAVE FIXED  
DOOR AND FACE FRAME ON END.  
BOTH SIDES OF STRAIGHT COLUMN  
HAVE FLUSH MITERED FINISHED ENDS.

BASE DEPTHS  
ON-U DEPTH: 24 7/8"  
AMENITY DEPTH: 24"  
WALL DEPTHS  
ON-U DEPTH: 12 7/8"  
AMENITY DEPTH: 12"

# 11-04 cabinet accessories fillers, panels - columns

## REEDED OVERLAY



ABBREVIATION  
 WALL REEDED OVERLAY 3" WORD3  
 BASE REEDED OVERLAY 3" BORD3  
 TALL REEDED OVERLAY 3" TORD3  
 WALL REEDED OVERLAY 4 1/2" WORD4.5  
 BASE REEDED OVERLAY 4 1/2" BORD4.5  
 TALL REEDED OVERLAY 4 1/2" TORD4.5  
 ONLY AVAILABLE UP TO 96" HIGH

REEDED FILLERS HAVE FULL LENGTH REEDED DETAIL. OUTSIDE EDGES ARE ROUND - NO OUTSIDE EDGE PROFILE.

## FILLER WITH DOUBLE RETURNS

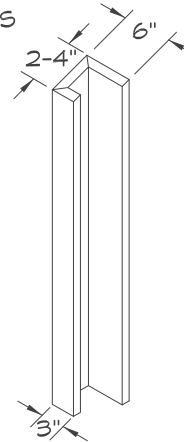

ABBREVIATION  
 N/A  
 WALL TO 43"  
 WALL TO 66"  
 BASE  
 TALL TO 84"  
 TALL TO 96"

WILL BE PRICED UP TO 6", 12", 18", AND 24" RETURNS.

## END PANEL



ABBREVIATION  
 WALL END PANEL WEPP  
 WALL TO 43" HT  
 WALL 44" TO 60"  
 BASE END PANEL BEPP  
 TALL END PANEL TEPF  
 TALL 12 7/8" DEEP (UP TO 96")  
 TALL 24 7/8" DEEP (UP TO 96")  
 TALL 30 7/8" DEEP (UP TO 96")

END PANELS COME WITH TWO FINISHED SIDES.

BASE DEPTHS  
 ONU DEPTH: 24 7/8"  
 AMENITY DEPTH: 24"  
 WALL DEPTHS  
 ONU DEPTH: 12 7/8"  
 AMENITY DEPTH: 12"

## BASE END PANEL/FILLER PENINSULA

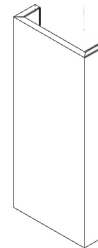

ABBREVIATION  
 BEPF-P

END PANELS WITH FILLERS COME WITH ONE FINISHED SIDE. SPECIFY 1-1/2" OR 3" FILLER.

## END PANEL/FILLER

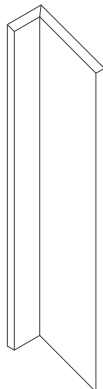

ABBREVIATION  
 WALL END PANEL/FILLER WEFP  
 WALL TO 43" HT  
 WALL 44" TO 60"  
 WALL 13" DEEP  
 WALL 13 7/8" DEEP  
 BASE END PANEL/FILLER BEFP  
 TALL END PANEL/FILLER TEPF  
 TALL 12" DEEP  
 TALL 24" DEEP  
 TALL 30" DEEP  
 TALL END PANEL  
 TALL 12 7/8" DEEP (UP TO 96")  
 TALL 24 7/8" DEEP (UP TO 96")  
 TALL 30 7/8" DEEP (UP TO 96")

END PANELS WITH FILLERS COME WITH ONE FINISHED SIDE. FLUSH TOE IS STANDARD ON BASE AND TALL END PANELS. SPECIFY TOE KICK NOTCH. SPECIFY 1 1/2" OR 3" FILLER.

## MITERED SHELF

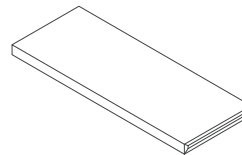

ABBREVIATION  
 1 1/2" HIGH MITERED SHELF  
 UP TO 6" DEEP MTS 1.5 X 6 X \_\_\_  
 UP TO 9" DEEP  
 UP TO 12" DEEP  
 2" HIGH MITERED SHELF  
 UP TO 6" DEEP MTS 2 X 6 X \_\_\_  
 UP TO 9" DEEP  
 UP TO 12" DEEP  
 3" HIGH MITERED SHELF  
 UP TO 6" DEEP MTS 3 X 6 X \_\_\_  
 UP TO 9" DEEP  
 UP TO 12" DEEP

2" HIGH VENEERED SHELF (SPECIFY FINISH LEFT/RIGHT)  
 MELAMINE, ACRYLIC, AND FOIL WILL ALWAYS BE BUTT JOINTED, NOT MITERED.

FILLER



FILLERS ARE FINISHED OR EDGEBANDED ON ALL FOUR EDGES

ABBREVIATION

- WALL FILLER 3" (UP TO 60") WF3
- BASE FILLER 3" BF3
- TALL FILLER 3" (UP TO 96") TF3
- WALL FILLER 6" (UP TO 60") WF6
- BASE FILLER 6" BF6
- TALL FILLER 6" (UP TO 96") TF6

ANGLED FILLER

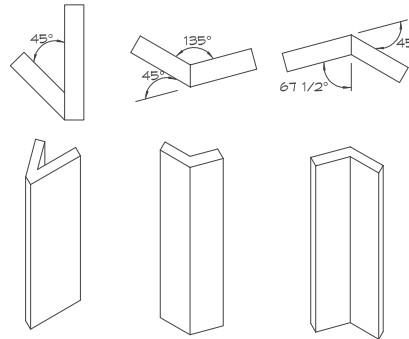

ABBREVIATION

- F3-HT-ANGLE
- EX: F3-42-22 1/2°

UP TO 48" HIGH  
49-96" HIGH  
MAY BE ORDERED  
IN 22 1/2" AND 135°

OVERLAY FILLER

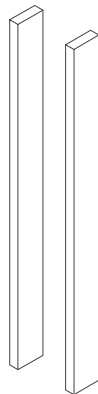

OVERLAY FILLERS ARE ROUTED AND/OR EDGE BANDED ON ALL FOUR EDGES TO MATCH DOOR EDGE PROFILE.

ABBREVIATION

- WALL OVERLAY FILLER 3" (UP TO 60") WOF3
- BASE OVERLAY FILLER 3" BOF3
- TALL OVERLAY FILLER 3" (UP TO 96") TOF3
- WALL OVERLAY FILLER 6" (UP TO 60") WOF6
- BASE OVERLAY FILLER 6" BOF6
- TALL OVERLAY FILLER 6" (UP TO 96") TOF6

FLUTED FILLER

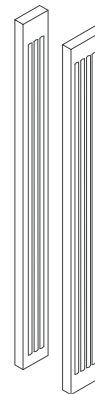

FLUTED FILLERS ARE FINISHED OR EDGE BANDED ON ALL FOUR EDGES - NO OUTSIDE EDGE PROFILES.

ABBREVIATION

- WALL FLUTED FILLER 3" (UP TO 60") WFF3
- BASE FLUTED FILLER 3" BFF3
- TALL FLUTED FILLER 3" (UP TO 96") TFF3
- WALL FLUTED FILLER 6" (UP TO 60") WFF6
- BASE FLUTED FILLER 6" BFF6
- TALL FLUTED FILLER 6" (UP TO 96") TFF6

CORNER FILLER



ABBREVIATION

- CORNER FILLER CF3X3
- CORNER OVERLAY FILLER N/A
- ORDER TWO OVERLAY FILLERS TO BE ASSEMBLED ON JOBSITE

FLUTED OVERLAY



OVERLAY FILLERS ARE FINISHED AND/OR EDGE BANDED ON ALL FOUR EDGES TO MATCH DOOR EDGE PROFILE. FILLER MUST BE PURCHASED SEPARATELY.

3 FLUTES STANDARD ON 3" WIDE FILLERS AND OVERLAY FILLERS  
5 FLUTES STANDARD ON 6" WIDE FILLERS AND OVERLAY FILLERS

ABBREVIATION

- WALL FLUTED OVERLAY 3" (UP TO 60") WOF3
- BASE FLUTED OVERLAY 3" BOF3
- TALL FLUTED OVERLAY 3" (UP TO 96") TOF3
- WALL FLUTED OVERLAY 6" (UP TO 60") WOF6
- BASE FLUTED OVERLAY 6" BOF6
- TALL FLUTED OVERLAY 6" (UP TO 96") TOF6

# 11-06 cabinet accessories fillers, panels - columns

## COLUMN WITH 3" ANGLE

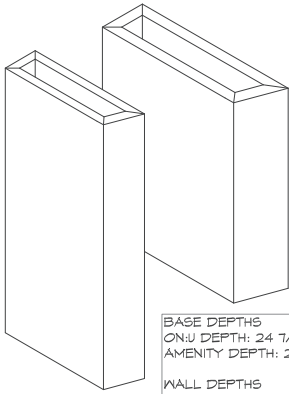

BASE DEPTHS  
ON-U DEPTH: 24 7/8"  
AMENITY DEPTH: 24"  
WALL DEPTHS  
ON-U DEPTH: 12 7/8"  
AMENITY DEPTH: 12"

### ABBREVIATION

WALL WCA  
BASE BCA  
TALLS  
12 7/8" (UP TO 96") TCA  
24 7/8" (UP TO 96") TCA  
12 7/8" DEEP (97-120" HIGH)  
24 7/8" DEEP (97-120" HIGH)  
30 7/8" DEEP (97-120" HIGH)  
36" BASE PENINSULA BCA-P

BOTH SIDES OF COLUMNS  
ARE FINISHED. SHORT  
SIDE HAS FLUSH FINISHED  
END AND LONG SIDE HAS  
STANDARD FINISHED END.

## GABLE - FLAIN OR DECORATIVE

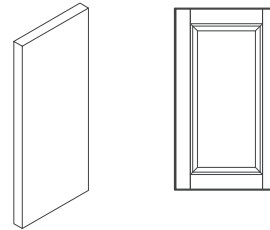

### ABBREVIATION N/A

GABLE END, FLAIN-  
3/4" PANEL COVERED  
TWO SIDES AND EDGE-  
BAND TO MATCH WOOD  
AND COLOR OF CABINET  
ORDER.

GABLE END, DECORATIVE-  
THIS IS A DOOR THAT  
MATCHES THE FRONT OF  
THE CABINET. DOOR WILL  
BE OVERSIZED TO BE  
FLUSH WITH FRONT OF  
CABINET DOORS.  
DECORATIVE GABLE IS  
FINISHED BOTH SIDES.

NOTE: THERE WILL BE 1/8"  
GAP BETWEEN DECORATIVE  
DOORS ON A TALL CABINET  
SIDE.

## COLUMN WITH 3" ANGLE FLUTED

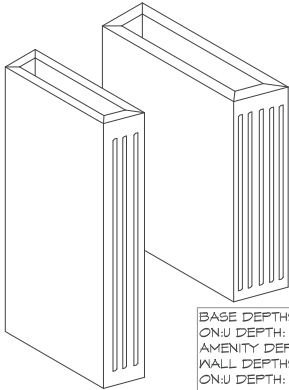

BASE DEPTHS  
ON-U DEPTH: 24 7/8"  
AMENITY DEPTH: 24"  
WALL DEPTHS  
ON-U DEPTH: 12 7/8"  
AMENITY DEPTH: 12"

### ABBREVIATION

WALL WCAF  
BASE BCAF  
TALLS  
12 7/8" (UP TO 96") TCAF  
24 7/8" (UP TO 96") TCAF  
30 7/8" (UP TO 96") TCAF  
36" BASE PENINSULA BCA-P

BOTH SIDES OF COLUMNS  
ARE FINISHED. SHORT  
SIDE HAS FLUSH FINISHED  
END AND LONG SIDE HAS  
STANDARD FINISHED END.

## PANELING

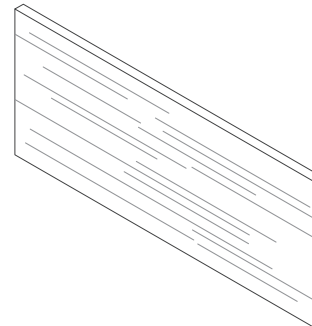

### ABBREVIATION

PL  
1/4"  
1/2"  
3/4"  
EDGE BAND ON 1/2" & 3/4"  
THICKNESS ONLY  
FINISH ONE SIDE

TO ORDER, SPECIFY THICKNESS  
X LENGTH X HEIGHT. GRAIN WILL  
RUN WITH THE HEIGHT.  
EXAMPLE: 3/4 X 34 1/2 X 96"

## 3" ANGLED COLUMN WITH INTEGRAL WAINSCOT END

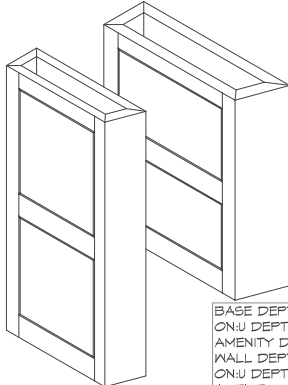

BASE DEPTHS  
ON-U DEPTH: 24 7/8"  
AMENITY DEPTH: 24"  
WALL DEPTHS  
ON-U DEPTH: 12 7/8"  
AMENITY DEPTH: 12"

### ABBREVIATION

WALL WCA-IWE-L/R  
BASE BCA-IWE-L/R  
TALLS  
12 7/8" (UP TO 96") TCA-IWE-L/R  
24 7/8" (UP TO 96") TCA-IWE-L/R  
30 7/8" (UP TO 96") TCA-IWE-L/R  
36" BASE PENINSULA BCA-P-IWE-L/R

WAINSCOT END DOES NOT INCREASE  
WIDTH OF COLUMN.  
CENTER PANEL WILL ALIGN WITH  
DOOR ON FRONT OF CABINET.  
TALL AND BASE COLUMNS HAVE  
WIDE BOTTOM RAILS.  
INSET STYLING WILL HAVE FIXED  
DOOR AND FACE FRAME ON END.  
BOTH SIDES OF STRAIGHT COLUMN  
HAVE FLUSH MITERED FINISHED ENDS.

## VERTICAL GRAIN PANELING

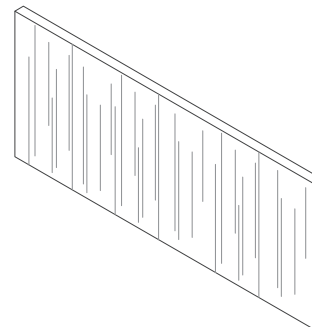

### ABBREVIATION

CGPL  
CGPL 1/4" X 96" X 34 1/2"  
CGPL 3/4" X 96" X 34 1/2"  
CGPL 1/4" X 96" X 48"  
CGPL 3/4" X 96" X 48"  
EDGE BAND ON 1/2" & 3/4"  
THICKNESS ONLY  
FINISH ONE SIDE

TO ORDER, SPECIFY THICKNESS  
X LENGTH X HEIGHT. GRAIN WILL  
RUN WITH THE LENGTH.  
EXAMPLE: 3/4 X 96 X 34 1/2"



cabinet accessories  
beadboard panels

11-07

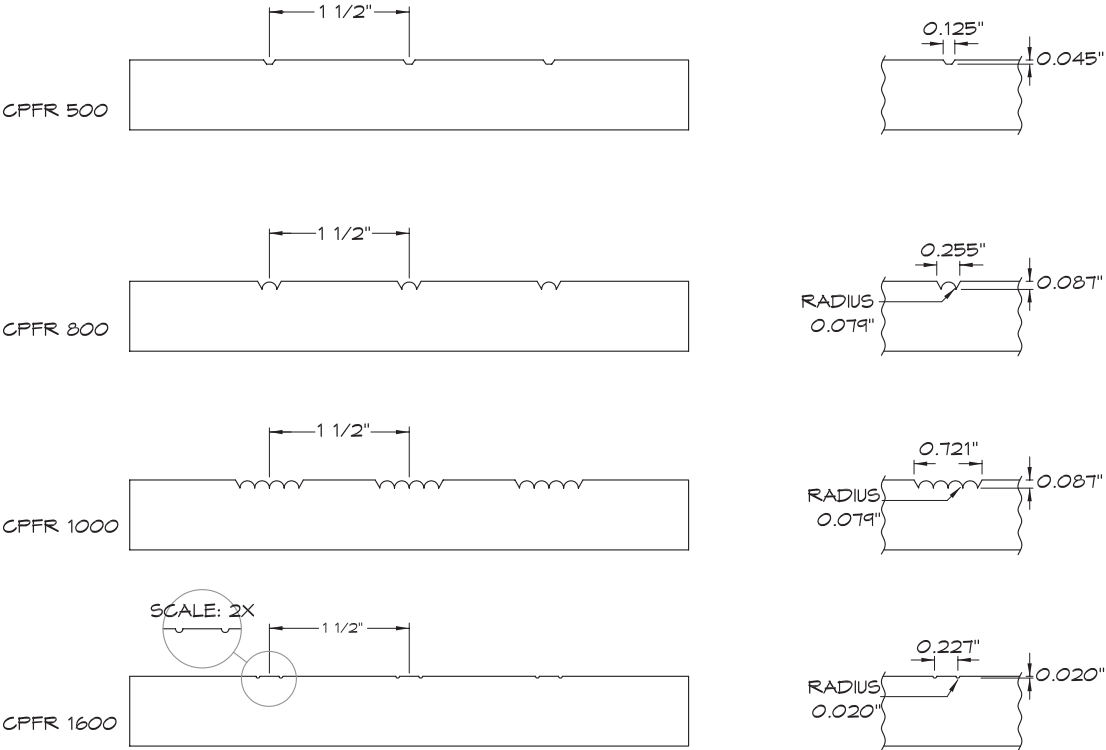

# 11-08 cabinet accessories

## fillers, panels - decorative appliance panels, valances

### DECORATIVE APPLIANCE PANELS

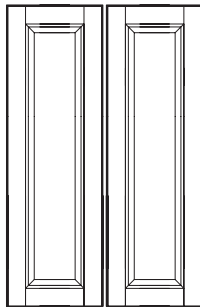

STYLE A

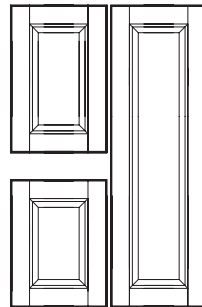

STYLE B

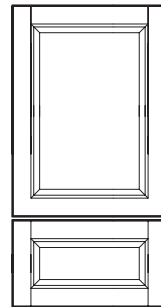

STYLE C

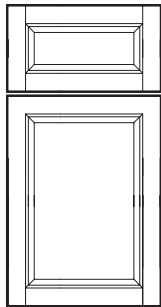

STYLE D

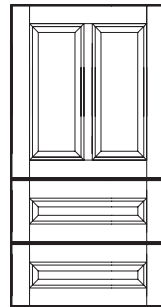

STYLE E

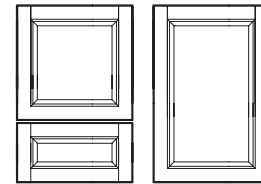

### ABBREVIATION

REFRIGERATOR FRONT RFP  
 DISHWASHER FRONT DFP  
 COMPACTOR FRONT CFP

SPECIFY IF A BACKER PANEL IS NEEDED.

ADD "PIN" MODIFICATION TO ATTACH DOOR AND DRAWER FRONT.

ALL APPLIANCE PANELS CAN BE ATTACHED TO A NOMINAL 1/4" PLYWOOD PANEL OR HAVE A LOOSE BACKER PANEL MADE AS PER SPECIFICATIONS.

APPLIANCE DETAIL FORM MUST BE SUBMITTED WITH ORDER SHOWING COMPLETE INFORMATION FOR REVEALS AND HANDLE PLACEMENTS OR ORDER WILL BE RETURNED TO THE DEALER.

INSET STYLING WILL HAVE FIXED DOOR AND FACE FRAME.

### VALANCES

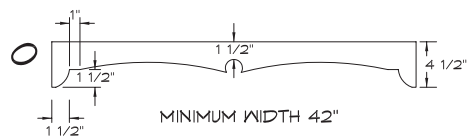
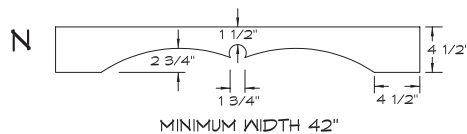
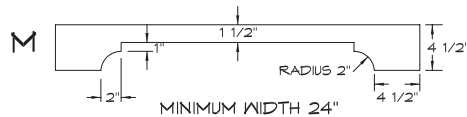
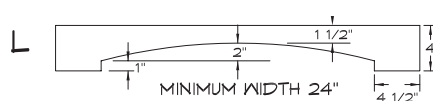
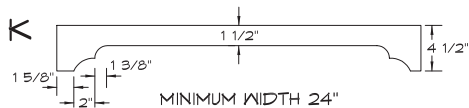
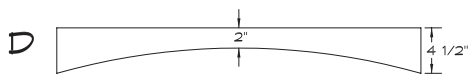
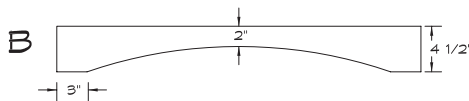
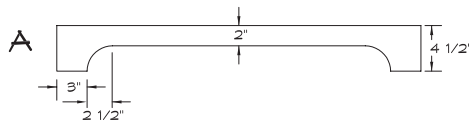

### ABBREVIATION

VAL-STYLE X WIDTH

4 1/2" HIGH VALANCES  
 24-47" WIDE  
 48-66" WIDE  
 67-96" WIDE

NOTE MINIMUM WIDTHS  
 NO EXCEPTIONS

VALANCES A-K  
 OGEE ROUT BOTTOMS

VALANCES L-X  
 SQUARE EDGE BOTTOMS



VALANCES

ABBREVIATION

VAL-STYLE X WIDTH  
5 1/2" HIGH VALANCES  
42-47" WIDE  
48-66" WIDE  
67-96" WIDE

NOTE MINIMUM WIDTHS  
NO EXCEPTIONS

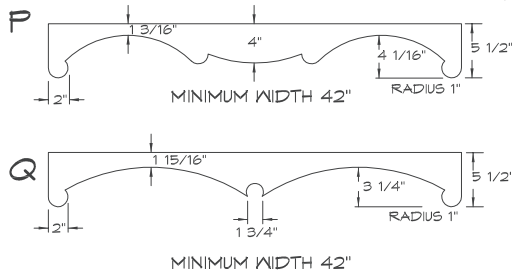

WINDSOR VALANCE

ABBREVIATION

VAL-W  
SQUARE RAISED OR FLAT PANEL  
MINIMUM VALANCE WIDTH AND  
HEIGHT WILL DEPEND ON THE  
DOOR STYLE CHOSEN TO MATCH.

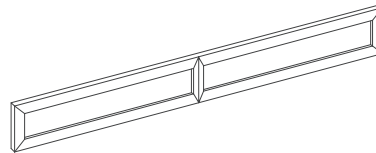

VALANCES

ABBREVIATION

VAL-STYLE X WIDTH  
4 1/2" HIGH VALANCES  
36-47" WIDE  
48-66" WIDE  
67-96" WIDE

NOTE MINIMUM WIDTHS  
NO EXCEPTIONS

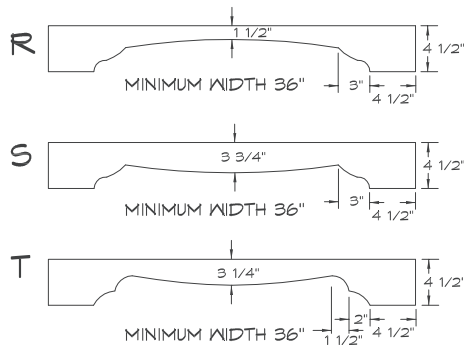

VALANCES

ABBREVIATION

VAL-STYLE X WIDTH  
8" HIGH VALANCES  
42-47" WIDE  
48-66" WIDE  
67-96" WIDE

NOTE MINIMUM WIDTHS  
NO EXCEPTIONS

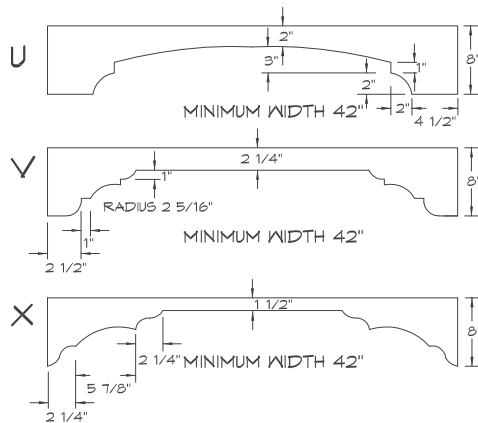

VENEER TOE KICK, 1/4"  
SOLID TOE KICK, 1/2"

ABBREVIATION

SSE-HEIGHT-PROFILE  
EXAMPLE:  
SSE-2-C

ALL MOULDINGS  
SOLD IN 96" LENGTHS

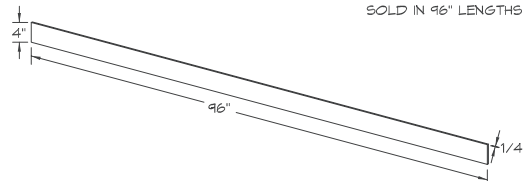

# 11-10 cabinet accessories

## fillers, panels - end caps, elegant corners, pilasters

ISLAND END CAP - A

ABBREVIATION  
IEC-A-(SIZE)

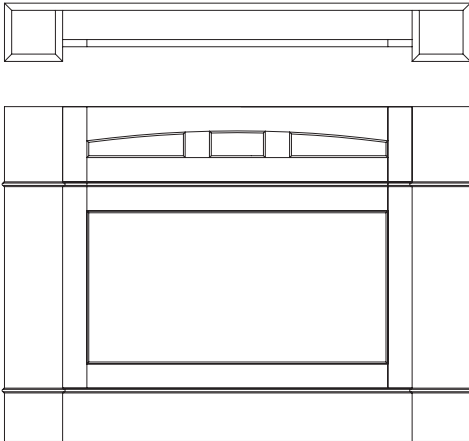

36" MINIMUM WIDTH  
DEPTH IS 6"  
ISLAND ENDCAP WILL BE  
FINISHED ON ALL SIDES  
(DOOR STYLE SPECIFIC)

ISLAND END CAP - C

ABBREVIATION  
IEC-C-(SIZE)

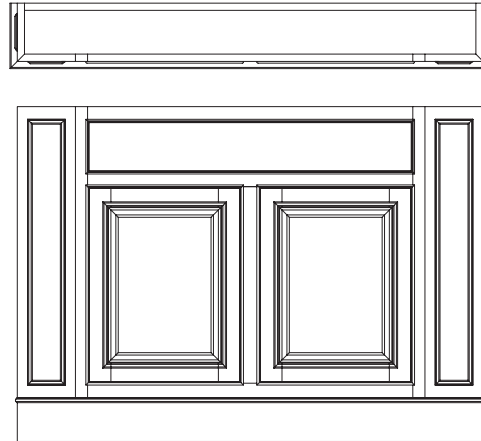

36" MINIMUM WIDTH  
DEPTH IS 6"  
ISLAND ENDCAP WILL BE  
FINISHED ON ALL SIDES  
(DOOR STYLE SPECIFIC)

ISLAND END CAP - B

ABBREVIATION  
IEC-B-(SIZE)

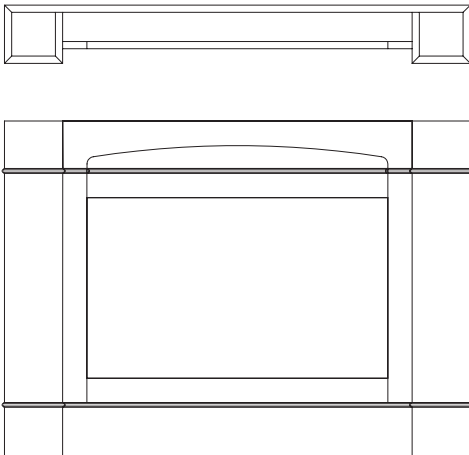

36" MINIMUM WIDTH  
DEPTH IS 6"  
ISLAND ENDCAP WILL BE  
FINISHED ON ALL SIDES  
(DOOR STYLE SPECIFIC)

ISLAND END CAP - D

ABBREVIATION  
IEC-D-(SIZE)

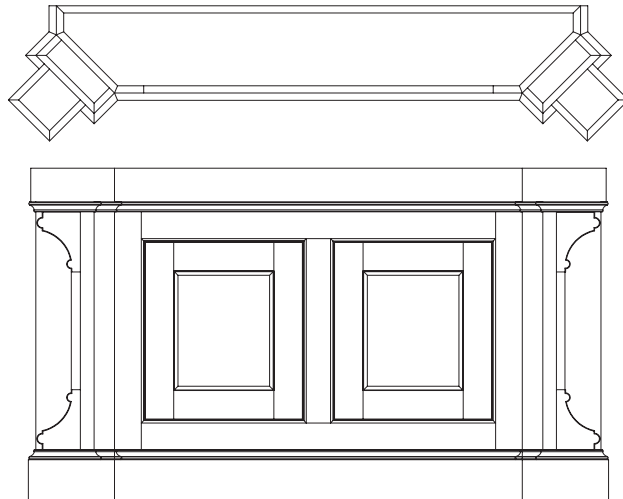

42" MINIMUM WIDTH  
DEPTH IS 11 1/8"  
ISLAND ENDCAP WILL BE  
FINISHED ON ALL SIDES  
(DOOR STYLE SPECIFIC)

fillers, panels - end caps, elegant corners, pilasters

ELEGANT CORNERS

ABBREVIATION  
ELC--(STYLE) X (HEIGHT)

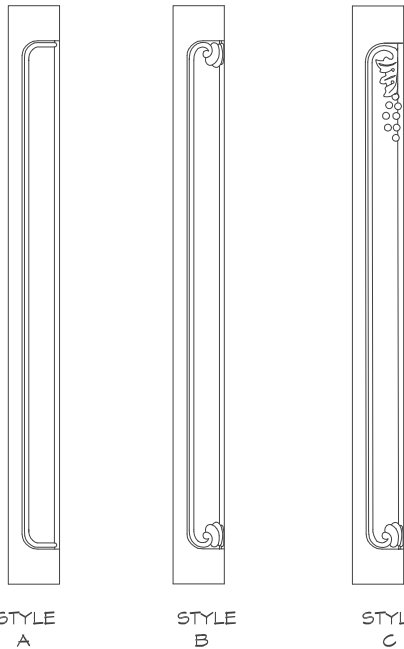

ALL ELEGANT CORNERS ARE AVAILABLE IN OAK, MAPLE, CHERRY, AND ALDER ONLY.

LIST PRICE INCLUDES BUILDING CORNER AS AN INTEGRAL PART OF A CABINET.

FLUSH FINISHED ENDS ARE NOT AVAILABLE WHEN USING AN ELEGANT CORNER APPLICATION.

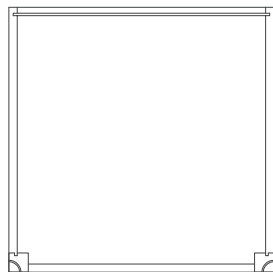

1 3/4 X 1 3/4 ELEGANT CORNER TOP VIEW

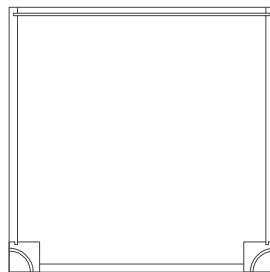

2 3/4 X 2 3/4 ELEGANT CORNER TOP VIEW

CORONET & CALAIS

CORONET

ABBREVIATION  
N/A

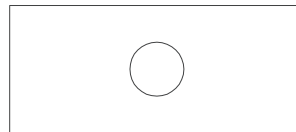

FRONT VIEW



SIDE VIEW

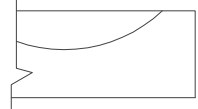

TOP DETAIL

CALAIS

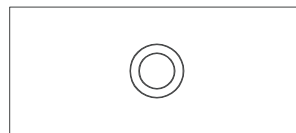

FRONT VIEW



SIDE VIEW

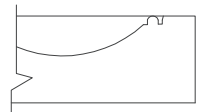

TOP DETAIL

CORONET AND CALAIS STATESMAN DRAWER FRONTS CAN BE ROUTED INTO ANY 3/4" SLAB DRAWER FRONT. ROUTS WILL BE CENTERED IN DRAWER FRONT OR CENTERED OVER DOORS ON DOUBLE DOOR CABINETS.

NOTE: CORONET AND CALAIS ROUTS ARE 2 3/4" IN DIAMETER AND 7/16" DEEP.

RECOMMENDED HARDWARE SHOULD HAVE HOLES DRILLED AT LEAST 5 1/16" CENTER TO CENTER OR 128 MM.

COUNTERTOP BRACKET

ABBREVIATION  
BRK-G

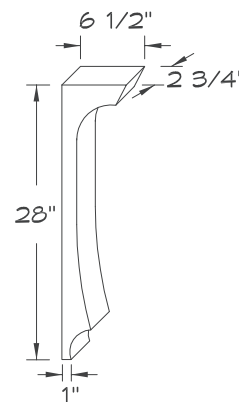

AVAILABLE FINISHES:  
OAK PAINT, MAPLE, BEECH,  
ALDER, CHERRY, R. ALDER

# 11-12 cabinet accessories fillers, panels, accessories

## BASE PILASTERS

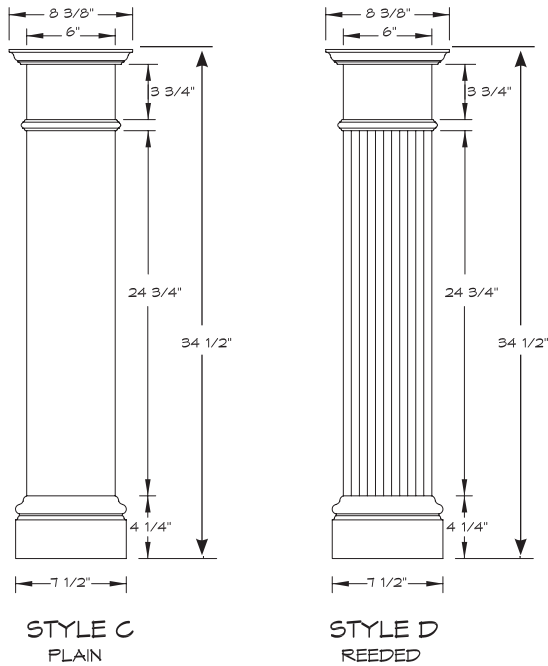
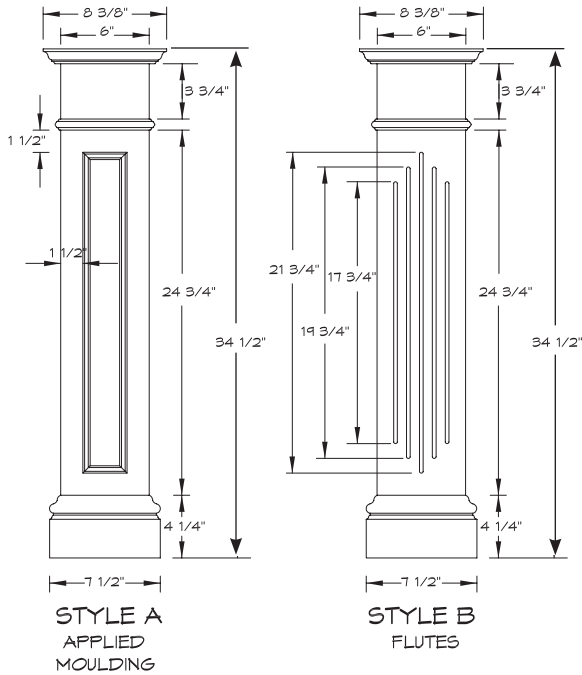

ABBREVIATION  
FIL-(STYLE)-(SIZE)

BASE PILASTER IS SHIPPED ASSEMBLED.

STYLE A: MIN. WIDTH IS 4 1/2"

STYLE B: MIN. WIDTH 3" FOR THREE FLUTES  
MIN. WIDTH 6" FOR FIVE FLUTES

STYLE C: MIN. WIDTH 3"

STYLE D: ONLY AVAILABLE IN 3" AND 4 1/2"  
WIDTHS

ALL STYLES: MOULDINGS ADD 2 1/2" IN WIDTH  
AND TOTAL OVERALL DEPTH IS 2"

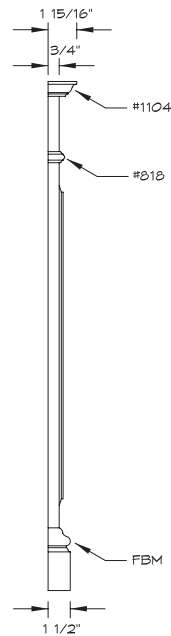

SECTION  
FOR ALL  
STYLES

CORBEL

ABBREVIATION

**BRC2**

AVAILABLE FINISHES -  
ALDER, CHERRY, HARD  
MAPLE

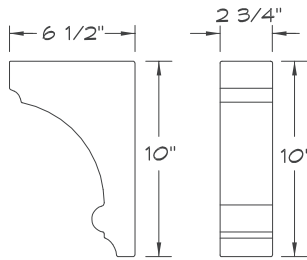

CORBEL

ABBREVIATION

**CBL-ML3**

AVAILABLE FINISHES -  
ALDER, CHERRY, HARD  
MAPLE

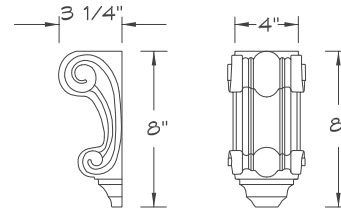

CORBEL

ABBREVIATION

**CBL-BR1**

AVAILABLE FINISHES -  
ALDER, CHERRY, HARD  
MAPLE

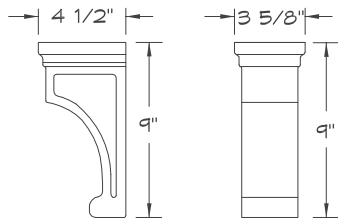

CORBEL

ABBREVIATION

**CBL-TB1**

AVAILABLE FINISHES -  
ALDER, CHERRY, HARD  
MAPLE

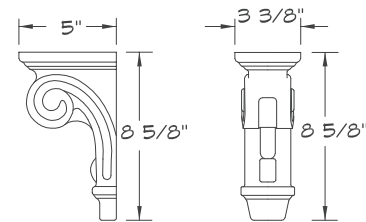

CORBEL

ABBREVIATION

**CBL-PN2**

AVAILABLE FINISHES -  
ALDER, CHERRY, HARD  
MAPLE

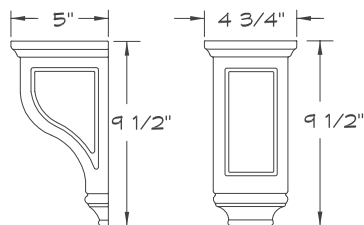

CORBEL

ABBREVIATION

**CBL-NBR1**

AVAILABLE FINISHES -  
ALDER, CHERRY, HARD  
MAPLE

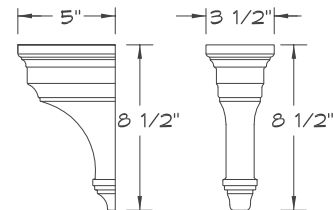

# 11-14 cabinet accessories fillers, panels, accessories

CORBEL

ABBREVIATION  
CBL-TR1

AVAILABLE FINISHES -  
ALDER, CHERRY, HARD  
MAPLE

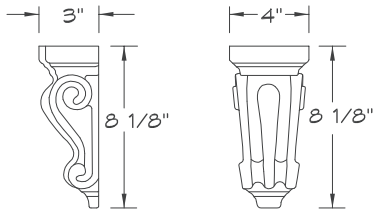

CORBEL

ABBREVIATION  
CBL-TRO

AVAILABLE FINISHES -  
ALDER, CHERRY, HARD  
MAPLE

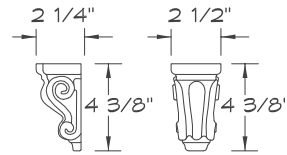

CORBEL

ABBREVIATION  
CBL-FLT1

AVAILABLE FINISHES -  
ALDER, CHERRY, HARD  
MAPLE

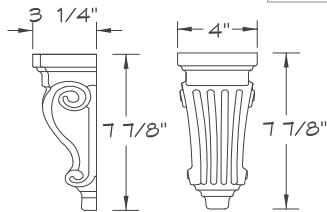

CORBEL

ABBREVIATION  
CBL-FR1

AVAILABLE FINISHES -  
ALDER, CHERRY, HARD  
MAPLE

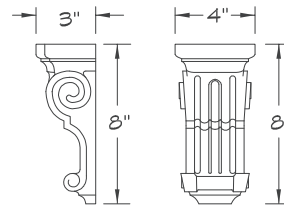

CORBEL

ABBREVIATION  
CBL-SH1

AVAILABLE FINISHES -  
ALDER, CHERRY, HARD  
MAPLE

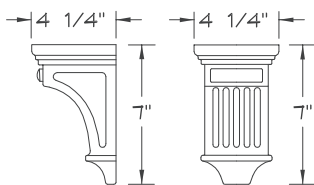

COASTAL SERIES  
CORNER BRACKETS

ABBREVIATION  
ACBR-6  
ACBR-12



AVAILABLE FINISHES -  
OAK PAINT, MAPLE, BEECH, ALDER,  
CHERRY, RUST. ALDER

ACBR-6: 3 1/4" W X 6 13/16" H X 4 1/2" D  
ACBR-12: 4 1/2" W X 12 3/8" H X 4" D