

# CLASSIC series doorstyles

Classic series

# NOTES

## Classic series 6-03 doorstyles

The CLASSIC SERIES will give you an exceptional value over a comparable style in the Elite Series or the You-Design-It Series. Pricing categories are shown below with **◆◆◆◆** the most expensive and **◆◆◆◆** the least expensive.

<b>CLASSIC SERIES DOORS and DRAWER OPTIONS</b>				
door name	standard drawer front	optional drawer front	inset hinge option**	construction
<b>FOUR DIAMONDS ◆◆◆◆</b>				
Flair raised panel	slab	5-part	yes	applied molding, m+t*
Flair reverse raised panel	slab	5-part	yes	applied molding, m+t*
Portrait raised panel	slab	5-part	yes	applied molding, m+t*
Portrait reverse raised panel	slab	5-part	yes	applied molding, m+t*
<b>TWO + 1/2 DIAMONDS ◆◆◆</b>				
Cannon reverse raised panel	slab	5-part	yes	m+t*
Ellsworth reverse raised panel	slab	5-part		m+t*
Frontenac raised panel	slab	5-part	yes	m+t*
Marshan reverse raised panel	slab	5-part	yes	m+t*
Ravenna reverse raised panel	slab	5-part	yes	m+t*

\* mortise and tenon

\*\* two options: beaded, non-beaded

NOTE: Price relates relates to doorstyle and is independent of finish selection.

# 6-04 Classic series cannon doorstyle

## CANNON RR

FULL OVERLAY / INSET

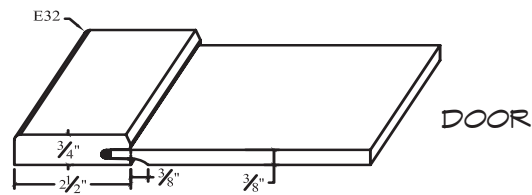
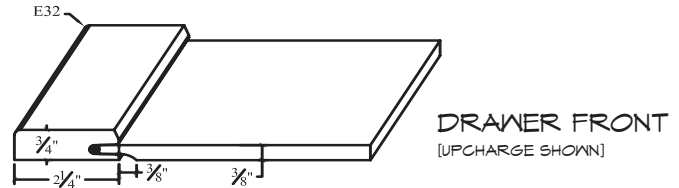

### DRAWER FRONT OPTIONS



SLAB [STANDARD]

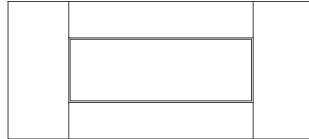

5-PIECE [UPCHARGE]

### DRAWER FRONT

OUTSIDE EDGE PROFILE	818	
PANEL PROFILE	690	
RAILS	708	
STILES	708	
APPLIED MOLDING	N/A	

### CONSTRUCTION

MORTISE AND TENON JOINTS  
3/8-INCH CENTER PANEL  
3/4-INCH THICK STILES AND RAILS  
2 1/2-INCH WIDE STILES AND RAILS

### EDGE TREATMENTS

### WOOD SPECIES

PLEASE SEE CHARTS ON PAGES 3-02 thru 3-04

### CENTER PANEL

MDF IN PAINTED FINISHES

### FINISHES

PLEASE SEE CHARTS ON PAGES 3-04 thru 3-06

### OPTIONS

REVERSE RAISED PANEL

### MINIMUM REQUIREMENTS

DOOR 8" X 8"  
DRAWER SLAB 8" X 6 3/4"  
DRAWER 5-PIECE 8" X 6 3/4"

NOTE: ALL TOP DRAWERS WITH A 5-PIECE FRONT WILL HAVE 2 1/2" STILES AND 2 1/4" RAILS

### DOOR

OUTSIDE EDGE PROFILE	818	
PANEL PROFILE	690	
RAILS	708	
STILES	708	
APPLIED MOLDING	N/A	

NOTE: Price relates relates to doorstyle and is independent of finish selection.

# ELLSWORTH RR

FULL OVERLAY / INSET

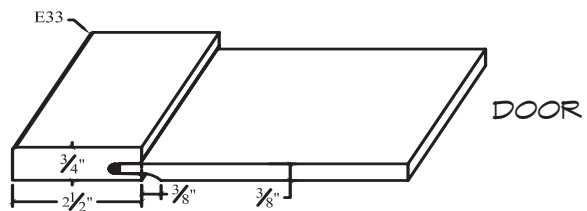
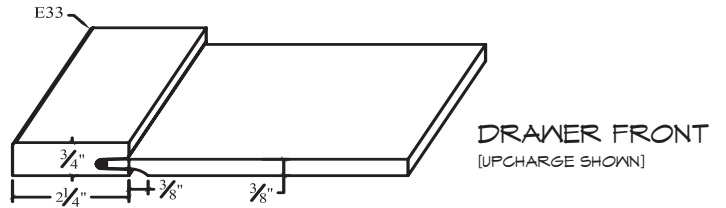

## DRAWER FRONT OPTIONS



SLAB [STANDARD]

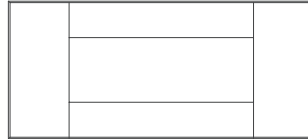

5-PIECE [UPCHARGE]

## DRAWER FRONT

OUTSIDE EDGE PROFILE	800	
PANEL PROFILE	690	
RAILS	701	
STILES	701	
APPLIED MOLDING	N/A	

## CONSTRUCTION

MORTISE AND TENON JOINTS  
3/8-INCH CENTER PANEL  
3/4-INCH THICK STILES AND RAILS  
2 1/2-INCH WIDE STILES AND RAILS

## EDGE TREATMENTS

## WOOD SPECIES

PLEASE SEE CHARTS ON PAGES 3-02 thru 3-04

## CENTER PANEL

MDF IN PAINTED FINISHES

## FINISHES

PLEASE SEE CHARTS ON PAGES 3-04 thru 3-06

## OPTIONS

## MINIMUM REQUIREMENTS

DOOR 8" X 8"  
DRAWER SLAB 8" X 6 3/4"  
DRAWER 5-PIECE 8" X 6 3/4"

NOTE: ALL TOP DRAWERS WITH A 5-PIECE FRONT WILL HAVE 2 1/2" STILES AND 2 1/4" RAILS

## DOOR

OUTSIDE EDGE PROFILE	800	
PANEL PROFILE	690	
RAILS	701	
STILES	701	
APPLIED MOLDING	N/A	

NOTE: Price relates relates to doorstyle and is independent of finish selection.

# 6-06 Classic series flair raised doorstyle

## FLAIR RAISED

FULL OVERLAY / INSET

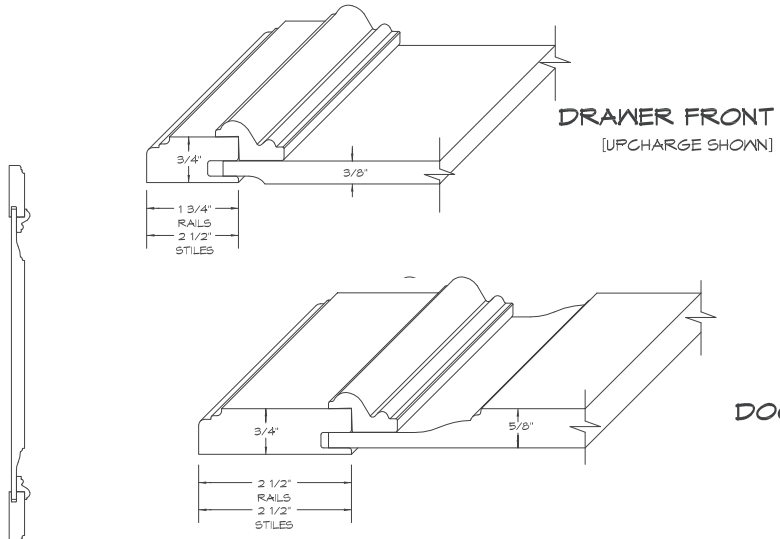

### DRAWER FRONT OPTIONS



SLAB [STANDARD]



5-PIECE [UPCHARGE]

### DRAWER FRONT

OUTSIDE EDGE PROFILE	896	
PANEL PROFILE	690	
RAILS	701D	
STILES	701D	
APPLIED MOLDING	AP102	

### CONSTRUCTION

MORTISE & TENON, APPLIED MOULDING  
5/8-INCH THICK CENTER PANEL  
3/4-INCH THICK STILES AND RAILS  
2 1/2-INCH WIDE STILES AND RAILS  
- PLUS MOULDING (3 3/8")

### CENTER PANEL

MDF IN PAINTED FINISHES

### OPTIONS

### EDGE TREATMENTS

### WOOD SPECIES

PLEASE SEE CHARTS ON PAGES 3-02 thru 3-04

### FINISHES

PLEASE SEE CHARTS ON PAGES 3-04 thru 3-06

### MINIMUM REQUIREMENTS

DOOR 12 1/2" X 12 1/2"  
DRAWER SLAB 9 1/2" X 6 3/4"  
DRAWER 5-PIECE 9 1/2" X 6 3/4"

NOTE: ALL TOP DRAWERS WILL HAVE 2 1/2"  
STILES AND 1 3/4" RAILS

### DOOR

OUTSIDE EDGE PROFILE	896	
PANEL PROFILE	621	
RAILS	701D	
STILES	701D	
APPLIED MOLDING	AP102	

NOTE: Price relates relates to doorstyle and is independent of finish selection.

Classic series 6-07  
flair reverse raised doorstyle

FLAIR RR

FULL OVERLAY / INSET

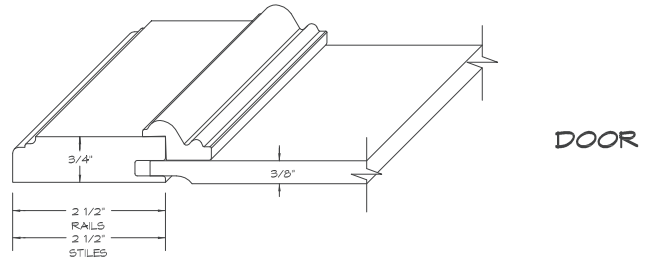
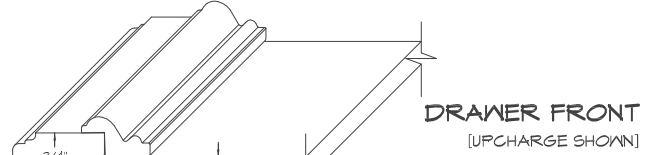

DRAWER FRONT OPTIONS



SLAB [STANDARD]



5-PIECE [UPCHARGE]

DRAWER FRONT

OUTSIDE EDGE PROFILE	896	
PANEL PROFILE	680	
RAILS	701D	
STILES	701D	
APPLIED MOULDING	AP102	

CONSTRUCTION

MORTISE & TENON  
APPLIED MOULDING  
3/8-INCH THICK CENTER PANEL  
3/4-INCH THICK STILES AND RAILS  
2 1/2-INCH WIDE STILES AND RAILS  
- PLUS MOULDING (3 3/8")

CENTER PANEL

MDF IN PAINTED FINISHES

OPTIONS

EDGE TREATMENTS

WOOD SPECIES

PLEASE SEE CHARTS ON PAGES 3-02 thru 3-04

FINISHES

PLEASE SEE CHARTS ON PAGES 3-04 thru 3-06

MINIMUM REQUIREMENTS

DOOR 9 1/2" X 9 1/2"  
DRAWER SLAB 8" X 6 3/4"  
DRAWER 5-PIECE 8" X 6 3/4"

NOTE: ALL TOP DRAWERS WILL HAVE 2 1/2" STILES AND 1 3/4" RAILS

DOOR

OUTSIDE EDGE PROFILE	896	
PANEL PROFILE	680	
RAILS	701D	
STILES	701D	
APPLIED MOULDING	AP102	

NOTE: Price relates relates to doorstyle and is independent of finish selection.

6-08 Classic series  
frontenac raised panel

# FRONTENAC RAISED

FULL OVERLAY / INSET

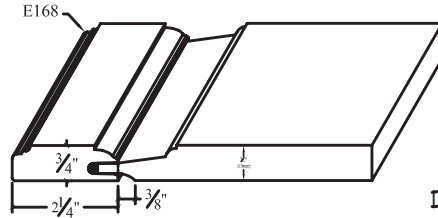

**DRAWER FRONT**  
[UPCHARGE SHOWN]

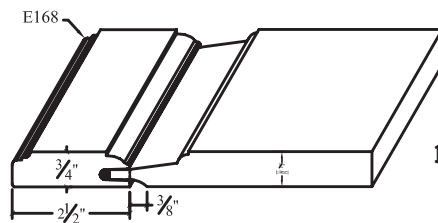

**DOOR**

## DRAWER FRONT OPTIONS



SLAB [STANDARD]

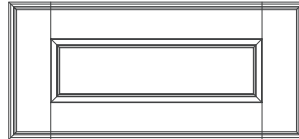

5-PIECE [UPCHARGE]

## DRAWER FRONT

OUTSIDE EDGE PROFILE	896	3/4"
PANEL PROFILE	690	
RAILS	704	2 1/4"
STILES	704	2 1/2"
APPLIED MOLDING	N/A	

## CONSTRUCTION

MORTISE AND TENON JOINTS  
5/8-INCH CENTER PANEL  
3/4-INCH THICK STILES AND RAILS  
2 1/2-INCH WIDE STILES AND RAILS

## CENTER PANEL

MDF IN PAINTED FINISHES

## OPTIONS

## EDGE TREATMENTS

## WOOD SPECIES

PLEASE SEE CHARTS ON PAGES 3-02 thru 3-04

## FINISHES

PLEASE SEE CHARTS ON PAGES 3-04 thru 3-06

## MINIMUM REQUIREMENTS

DOOR 10 3/4" X 10 3/4"  
DRAWER SLAB 8" X 6 3/4"  
DRAWER 5-PIECE 8" X 6 3/4"

NOTE: ALL TOP DRAWERS WITH A 5-PIECE FRONT WILL HAVE 2 1/2" STILES AND 2 1/4" RAILS

## DOOR

OUTSIDE EDGE PROFILE	896	3/4"
PANEL PROFILE	621	5/8"
RAILS	704	2 1/2"
STILES	704	2 1/2"
APPLIED MOLDING	N/A	

NOTE: Price relates relates to doorstyle and is independent of finish selection.



Classic series 6-09  
 marshan reverse raised doorstyle

MARSHAN RR

FULL OVERLAY / INSET

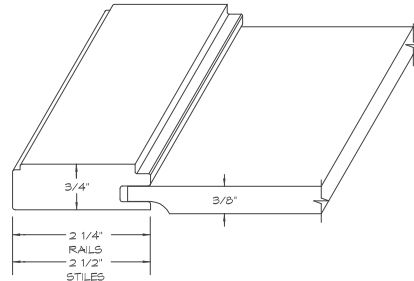

DRAWER FRONT  
 [UPCHARGE SHOWN]

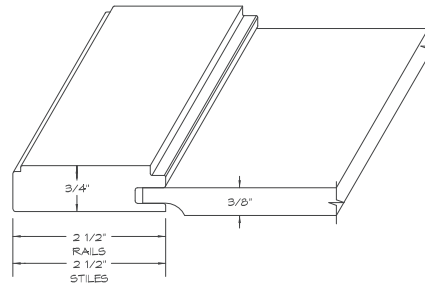

DOOR

DRAWER FRONT OPTIONS



SLAB [STANDARD]

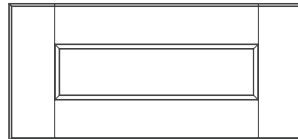

5-PIECE [UPCHARGE]

DRAWER FRONT

OUTSIDE EDGE PROFILE	805	
PANEL PROFILE	680	
RAILS	707	
STILES	707	
APPLIED MOLDING	N/A	

CONSTRUCTION

MORTISE AND TENON JOINTS  
 3/8-INCH CENTER PANEL  
 3/4-INCH THICK STILES AND RAILS  
 2 1/2-INCH WIDE STILES AND RAILS

EDGE TREATMENTS

WOOD SPECIES

PLEASE SEE CHARTS ON PAGES 3-02 thru 3-04

CENTER PANEL

MDF IN PAINTED FINISHES

FINISHES

PLEASE SEE CHARTS ON PAGES 3-04 thru 3-06

OPTIONS

MINIMUM REQUIREMENTS

DOOR 8" X 8"  
 DRAWER SLAB 8" X 6 3/4"  
 DRAWER 5-PIECE 8" X 6 3/4"

NOTE: ALL TOP DRAWERS WITH A 5-PIECE FRONT WILL HAVE 2 1/2" STILES AND 2 1/4" RAILS.

DOOR

OUTSIDE EDGE PROFILE	805	
PANEL PROFILE	680	
RAILS	707	
STILES	707	
APPLIED MOLDING	N/A	

NOTE: Price relates relates to doorstyle and is independent of finish selection.

6-10 Classic series  
portrait raised doorstyle

# PORTRAIT RAISED

FULL OVERLAY / INSET

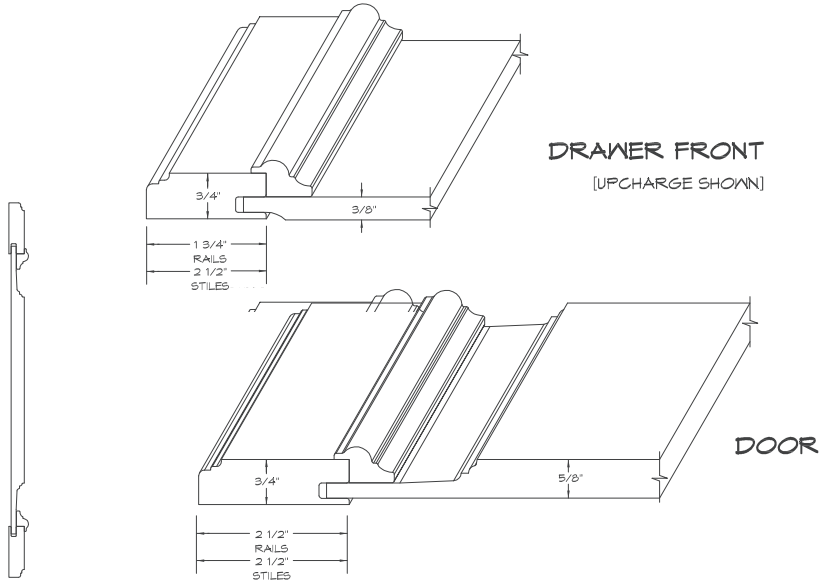

## DRAWER FRONT OPTIONS



SLAB [STANDARD]



5-PIECE [UPCHARGE]

## DRAWER FRONT

OUTSIDE EDGE PROFILE	896	
PANEL PROFILE	690	
RAILS	701D	
STILES	701D	
APPLIED MOLDING	AP126	

## CONSTRUCTION

MORTISE AND TENON JOINTS  
5/8-INCH CENTER PANEL  
3/4-INCH THICK STILES AND RAILS  
2 1/2-INCH WIDE STILES AND RAILS

## EDGE TREATMENTS

## WOOD SPECIES

PLEASE SEE CHARTS ON PAGES 3-02 thru 3-04

## CENTER PANEL

MDF IN PAINTED FINISHES

## FINISHES

PLEASE SEE CHARTS ON PAGES 3-04 thru 3-06

## OPTIONS

## MINIMUM REQUIREMENTS

DOOR 12 1/4" X 12 1/4"  
DRAWER SLAB 8" X 6 3/4"  
DRAWER 5-PIECE 8" X 6 3/4"

NOTE: ALL TOP DRAWERS WITH A 5-PIECE FRONT WILL HAVE 2 1/2" STILES AND 1 3/4" RAILS.

## DOOR

OUTSIDE EDGE PROFILE	896	
PANEL PROFILE	620	
RAILS	701D	
STILES	701D	
APPLIED MOLDING	AP126	

NOTE: Price relates relates to doorstyle and is independent of finish selection.

Classic series 6-11  
portrait doorstyle

PORTRAIT RR

FULL OVERLAY / INSET

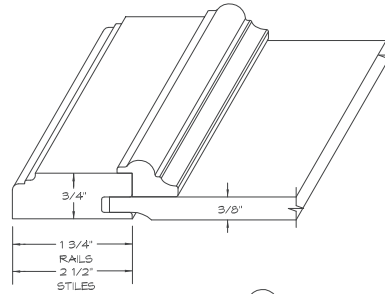

DRAWER FRONT  
[UPCHARGE SHOWN]

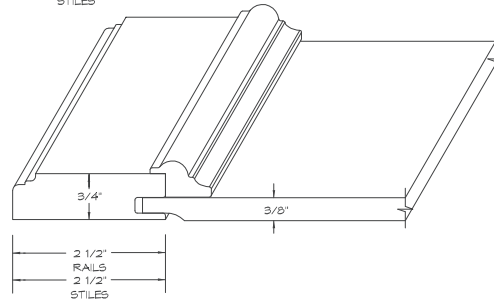

DOOR

DRAWER FRONT OPTIONS





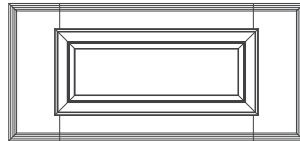

SLAB [STANDARD]

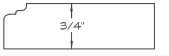

5-PIECE [UPCHARGE]

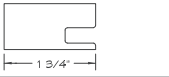
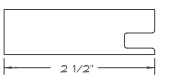
DRAWER FRONT

OUTSIDE EDGE PROFILE	896	
PANEL PROFILE	680	
RAILS	701D	
STILES	701D	
APPLIED MOLDING	AP126	

CONSTRUCTION

MORTISE AND TENON JOINTS  
3/8-INCH CENTER PANEL  
3/4-INCH THICK STILES AND RAILS  
2 1/2-INCH WIDE STILES AND RAILS

EDGE TREATMENTS

WOOD SPECIES

PLEASE SEE CHARTS ON PAGES 3-02 thru 3-04

CENTER PANEL

MDF IN PAINTED FINISHES

FINISHES

PLEASE SEE CHARTS ON PAGES 3-04 thru 3-06





OPTIONS

MINIMUM REQUIREMENTS

DOOR 9 1/2" x 9 1/2"  
DRAWER SLAB 8" x 6 3/4"  
DRAWER 5-PIECE 8" x 6 3/4"

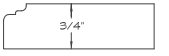
NOTE: ALL TOP DRAWERS WITH A 5-PIECE FRONT WILL HAVE 2 1/2" STILES AND 1 3/4" RAILS.

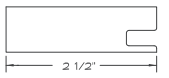
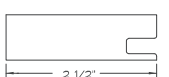
DOOR

OUTSIDE EDGE PROFILE	896	
PANEL PROFILE	680	
RAILS	701D	
STILES	701D	
APPLIED MOLDING	AP126	

NOTE: Price relates relates to doorstyle and is independent of finish selection.

# 6-12 Classic series ravenna doorstyle

## RAVENNA RR

FULL OVERLAY / INSET

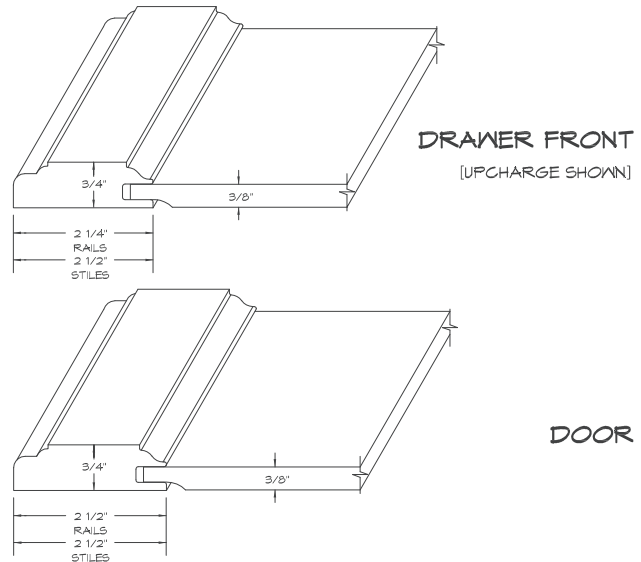

### DRAWER FRONT OPTIONS



SLAB [STANDARD]

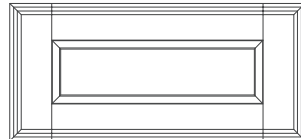

5-PIECE [UPCHARGE]

### DRAWER FRONT

OUTSIDE EDGE PROFILE	894	
PANEL PROFILE	680	
RAILS	702	
STILES	702	
APPLIED MOLDING	N/A	

### CONSTRUCTION

MORTISE AND TENON JOINTS  
3/8-INCH CENTER PANEL  
3/4-INCH THICK STILES AND RAILS  
2 1/2-INCH WIDE STILES AND RAILS

### EDGE TREATMENTS

### WOOD SPECIES

PLEASE SEE CHARTS ON PAGES 3-02 thru 3-04

### CENTER PANEL

MDF IN PAINTED FINISHES

### FINISHES

PLEASE SEE CHARTS ON PAGES 3-04 thru 3-06

### OPTIONS

### MINIMUM REQUIREMENTS

DOOR 8" X 8"  
DRAWER SLAB 8" X 6 3/4"  
DRAWER 5-PIECE 8" X 6 3/4"

NOTE: ALL TOP DRAWERS WITH A 5-PIECE FRONT WILL HAVE 2 1/2" STILES AND 2 1/4" RAILS

### DOOR

OUTSIDE EDGE PROFILE	894	
PANEL PROFILE	680	
RAILS	702	
STILES	702	
APPLIED MOLDING	N/A	

NOTE: Price relates relates to doorstyle and is independent of finish selection.

# FRAME DOORS

FULL OVERLAY / INSET

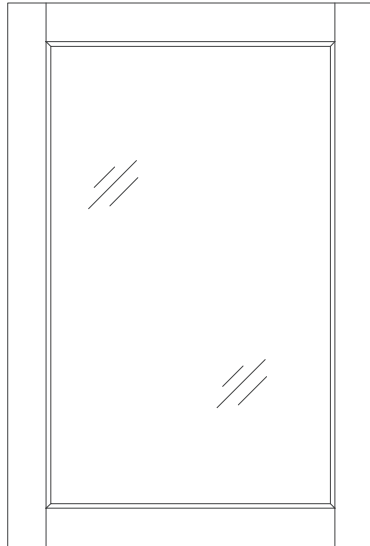

TO MATCH DOORSTYLE  
CONSTRUCTION

DRAWER  
FRONT

TO MATCH DOORSTYLE  
CONSTRUCTION

DOOR

## CONSTRUCTION

MATCHES EDGE AND PROFILE OF  
DOOR STYLE  
3/4-INCH THICK STILES AND RAILS  
2 1/2-INCH WIDE STILES AND RAILS  
GLASS IS NOT INCLUDED

## EDGE TREATMENTS

## WOOD SPECIES

PLEASE SEE CHARTS ON PAGES 3-02 thru 3-04

## CENTER PANEL

## FINISHES

PLEASE SEE CHARTS ON PAGES 3-04 thru 3-06

## OPTIONS

## MINIMUM REQUIREMENTS

DOOR: 8" X 8"

NOTES: 48" DOOR OR TALLER WILL HAVE AN  
INTERMEDIATE CENTER RAIL. FRAME DOOR  
IS NO CHARGE. DOES NOT INCLUDE  
COST OF FINISHED INTERIOR.

## DRAWER FRONT

OUTSIDE EDGE PROFILE	TO MATCH DOORSTYLE	
PANEL PROFILE	TO MATCH	
RAILS	TO MATCH	
STILES	TO MATCH	
APPLIED MOLDING	TO MATCH	

## DOOR

OUTSIDE EDGE PROFILE	TO MATCH DOORSTYLE	
PANEL PROFILE	TO MATCH	
RAILS	TO MATCH	
STILES	TO MATCH	
APPLIED MOLDING	TO MATCH	

6-14 Classic series  
mullion doorstyle

# MULLION DOORS

FULL OVERLAY / INSET

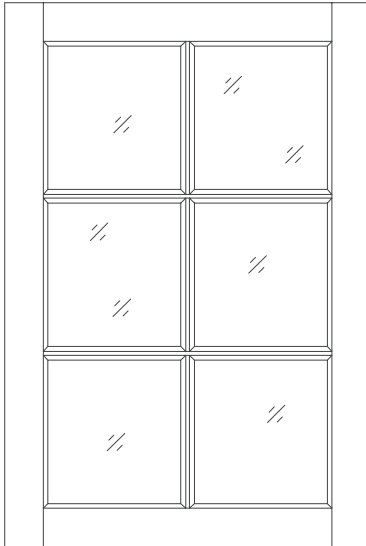

TO MATCH DOORSTYLE  
CONSTRUCTION

DRAWER  
FRONT

TO MATCH DOORSTYLE  
CONSTRUCTION

DOOR

### CONSTRUCTION

MATCHES EDGE AND PROFILE OF  
DOOR STYLE  
3/4-INCH THICK STILES AND RAILS  
GLASS IS NOT INCLUDED

### CENTER PANEL

### OPTIONS

### EDGE TREATMENTS

### WOOD SPECIES

PLEASE SEE CHARTS ON PAGES 3-02 thru 3-04

### FINISHES

PLEASE SEE CHARTS ON PAGES 3-04 thru 3-06

### MINIMUM REQUIREMENTS

DOOR: 8" X 8"

NOTES: MULLION DOOR IS AN UPCHARGE.  
DOES NOT INCLUDE COST OF FINISHED INTERIOR.

12" TO 27" HIGH 4 LITES  
28" TO 36" HIGH 6 LITES  
37" TO 48" HIGH 8 LITES

48" DOOR OR TALLER WILL HAVE AN  
INTERMEDIATE CENTER RAIL.

### DRAWER FRONT

OUTSIDE EDGE PROFILE	TO MATCH DOORSTYLE	
PANEL PROFILE	TO MATCH	
RAILS	TO MATCH	
STILES	TO MATCH	
APPLIED MOLDING	TO MATCH	

### DOOR

OUTSIDE EDGE PROFILE	TO MATCH DOORSTYLE	
PANEL PROFILE	TO MATCH	
RAILS	TO MATCH	
STILES	TO MATCH	
APPLIED MOLDING	TO MATCH	

# PRAIRIE MULLION

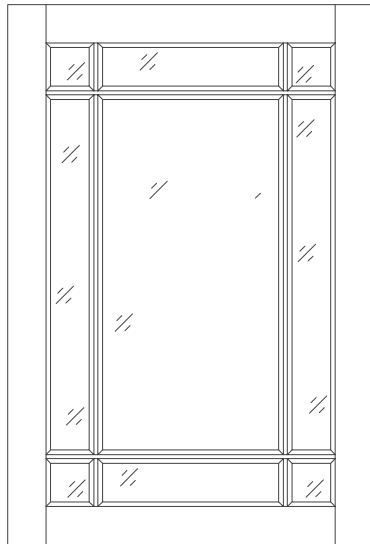

TO MATCH DOORSTYLE  
CONSTRUCTION

DRAWER  
FRONT

TO MATCH DOORSTYLE  
CONSTRUCTION

DOOR

## CONSTRUCTION

MATCHES EDGE AND PROFILE OF  
DOOR STYLE  
3/4-INCH THICK STILES AND RAILS  
GLASS IS NOT INCLUDED

## EDGE TREATMENTS

## WOOD SPECIES

PLEASE SEE CHARTS ON PAGES 3-02 thru 3-04

## CENTER PANEL

## FINISHES

PLEASE SEE CHARTS ON PAGES 3-04 thru 3-06

## OPTIONS

## MINIMUM REQUIREMENTS

DOOR: 14" X 18"

NOTES: 48" DOOR OR TALLER WILL HAVE AN  
INTERMEDIATE CENTER RAIL. PRAIRIE MULLION  
IS AN UPCHARGE. DOES NOT INCLUDE COST OF  
FINISHED INTERIOR.

## DRAWER FRONT

OUTSIDE EDGE PROFILE	TO MATCH DOORSTYLE	
PANEL PROFILE	TO MATCH	
RAILS	TO MATCH	
STILES	TO MATCH	
APPLIED MOLDING	TO MATCH	

## DOOR

OUTSIDE EDGE PROFILE	TO MATCH DOORSTYLE	
PANEL PROFILE	TO MATCH	
RAILS	TO MATCH	
STILES	TO MATCH	
APPLIED MOLDING	TO MATCH	

# 6-16 Classic series wainscoting



USING THE STILE AND RAIL CHOICES ALONG WITH THE CENTER PANEL OPTIONS FROM THE DESIGN YOUR OWN DOOR PROGRAM OR THE CLASSIC SERIES, YOU CAN DESIGN YOUR OWN MAINSCOTING.

## DESIGN CONSIDERATIONS:

STILES AND RAILS CAN BE UP TO 3" WIDE WITH ONE EXCEPTION: THE BOTTOM RAILS MAY BE UP TO 8 1/2" HIGH IF SPECIFIED.

MAXIMUM PANEL SIZES: W 96" X 42" H - OR - W 30" X 96" H

ONLY AVAILABLE IN MORTISE AND TENON STILES AND RAILS - NOT AVAILABLE IN MITERED.

FINISHED FRONTS AND ALL EDGES IS STANDARD. FINISHED BACK IS AT AN ADDITIONAL CHARGE.

EQUAL SPACING IS STANDARD. ADDITIONAL CHARGES APPLY FOR MODIFIED SPACING. FOR EXAMPLE: A 60/40 SPLIT.

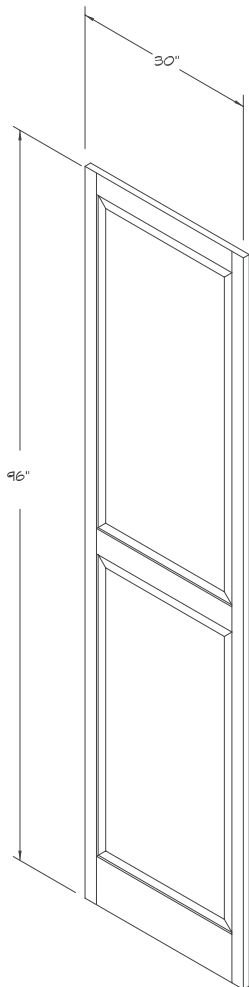

### NUMBER OF PANELS

- UP TO 36" - 1 PANEL
- UP TO 84" - 2 PANELS
- UP TO 96" - 2 OR 3 PANELS

GRATING CHARGES MAY APPLY FOR PANELS WITH DIMENSIONS EXCEEDING 90"

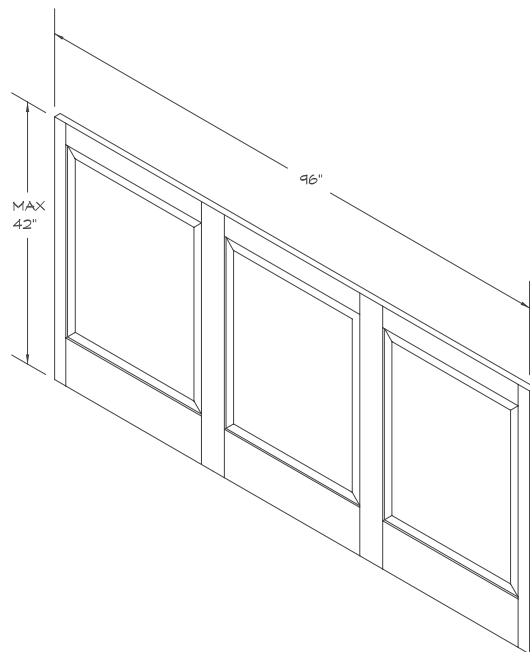

### NUMBER OF PANELS

- UP TO 30" - 1 PANEL
- 30" TO 54" - 2 PANELS
- 54" TO 96" - 3 PANELS

GRATING CHARGES MAY APPLY FOR PANELS WITH DIMENSIONS EXCEEDING 90"